

INSTALLATION, OPERATION & MAINTENANCE MANUAL

Guardian™ Breathing Airline Filter Station



MANUAL CONTENTS

	INTRODUCTION				
3	Description	11		FILTER SET SERVICE INSTRUCTIONS	
3	Features			Filter Set Service Instructions	
3	Specifications	13		RECORD KEEPING	
				Record Keeping	
	GENERAL SAFETY WARNINGS			SERVICE RECORD	
4	General Safety Warnings	14		Service Record	
				PERFORMANCE CURVES	
	GENERAL FILTER SYSTEM DESCRIPTION			Performance Curves	
5	General Filter System Description	15		REPLACEMENT PARTS	
				Replacement Parts	
	GENERAL OPERATIONS				
6	Introduction	17			
6	Customer Air Supply				
7	Initial Installation and Start-Up				
8	Air Sample To Monitor Adjustment				
9	General Operation and Maintenance				
10	Purification System				

WARNING

Do not attempt to operate this equipment without first reading and understanding the manual enclosed with this device. Suitability for use of this device lies solely with user.

Fill in your model and serial number in the blank spaces below. These can be used for reference whenever service or maintenance is required.

Unit Serial Number _____

Date Of Issue _____

INTRODUCTION

DESCRIPTION

The Blast-One Guardian AP CMF 5000 is a four stage purification system designed to reduce select contaminants (including carbon monoxide) that are found in compressed air lines, while monitoring for carbon monoxide through the monitor. The Guardian can be connected directly to air from a standard compressed air source to provide breathing quality air to face masks, helmets, hoods and other supply air breathing apparatus. The portability allows carrying the unit to each job site, or the complete unit can be wall mounted as supplied.

FEATURES

- Portable breathing air station with regulator
- Presented in rugged, protective carry case
- Four stage air purification system with carbon monoxide converter and continuous final-stage carbon monoxide monitoring with digital readout
- Inbuilt carbon monoxide warning alarm light and siren
- Powered by two 9 volt batteries (included)
- Optional 12 volt external power lead
- 50 cfm capacity provides air filtration and monitoring for two operators using climate control tubes (or four operators using flow control valves)
- Control zero gas and 95 ppm 'CO' calibration gas requires industry standard AS___ for calibration
- Easy on site calibration procedure
- Calibration kit includes calibration tool, zero gas, 95 ppm calibration gas, connector and tubing

SPECIFICATIONS

Maximum Inlet Pressure	150 psig STATIC (10.4 bar)
Maximum Rated Air Flow	50 scfm (23.6 L/s)
Operating Pressure	100 psig DYNAMIC (6.9 bar)
Outlet Pressure Range	0 - 125 psig (0 - 8.6 bar)
Operating Relative Humidity (inlet air)	30 - 100% RH
Operating Temperature Range (inlet air)	68 - 150°F (20 - 65°C)
Outside Dimensions	23.25"L x 20.75"W x 9"D (590mm x 527mm x 229mm)
Weight (including monitor)	31 lbs. (14.1 kg.)

The Blast-One Guardian Breathing Airline Filter Station (AP CMF 5000):

1. SHOULD NOT be used when the air entering the filtering system is oxygen deficient. The Guardian will not increase the oxygen content of the air.
2. SHOULD NOT be used in an 'Immediately Dangerous to Life and Health' atmosphere (IDLH) unless it is used in conjunction with a back-up escape system or a supply air self-contained breathing apparatus (SCBA), where applicable.
3. CARBON MONOXIDE MONITOR will alarm if Carbon Monoxide levels exceed requirements for Grade 'D' breathing air set forth by OSHA/CSA. If alarm should sound, remove respirator or activate SCBA and immediately move to safe breathable atmosphere. Have the proper qualified personnel examine the equipment and make the appropriate corrections before using again.
4. SHOULD NOT have air inlet pressure greater than 150 psig static (10.4 bar). Personal injury could result.
5. SHOULD NOT have air outlet pressure that exceeds the manufacturers' respirator/hose assembly pressure requirements. Personal injury could result.

WARNING

Carbon Monoxide (CO) is a lethally dangerous gas – being colourless and odourless it poses a serious risk to the wearer of an air supply respirator because it will not be detected. Monitoring equipment is essential to safeguard the breathing air.

GENERAL FILTER SYSTEM DESCRIPTION

(Refer to Figure 1)

Air entering the Blast-One Guardian at the inlet **(A)** is usually contaminated with oil, water, dirt, rust, scale, gaseous hydrocarbons and often deadly carbon monoxide. As the air passes through the first stage **(B)** of the Guardian prefilter, solid particulate matter of three microns and larger are trapped by a high surface area pleated filter media. The air then passes through the second stage **(C)** of the prefilter, which traps all particulate matter larger than 0.3 micron and coalesces liquid aerosols with an efficiency rating of 99.97% (D.O.P., 0.3 - 0.6 microns).

The prefilter meets Underwriters Laboratories Specification UL 586 for high efficiency, particulate, air filter units (HEPA rating). The liquid contaminates are trapped in the lower chamber of the prefilter and expelled out through the automatic float drain **(D)**. The third stage **(E)** contains a deep bed of odour absorbing activated charcoal which collects various gaseous hydrocarbons (such as oil vapours, benzene, etc.).

The fourth stage **(F)** contains a low temperature catalyst which converts carbon monoxide gas into carbon dioxide. The unique catalyst also converts or absorbs ozone, nitric oxide, sulphur dioxide, nitrogen dioxide, Hydrogen Sulphide, Ammonia, Acetaldehyde, Methyl Chloride, Methyl Ethyl Ketone, Acetone and Methyl Alcohol. The air then passes through a one micron filter disc **(G)** before entering the regulator **(H)**, which is used to adjust the air pressure passing to the respirator(s).

A sample of the filtered air is taken at **(I)** and passed through the carbon monoxide monitor **(J)**.

The monitor continuously checks the carbon monoxide levels per OSHA/CSA requirements and digitally displays the amount present in ppm, (parts per million). An audible and visual alarm will alert operators if levels of carbon monoxide exceed OSHA/CSA limits.

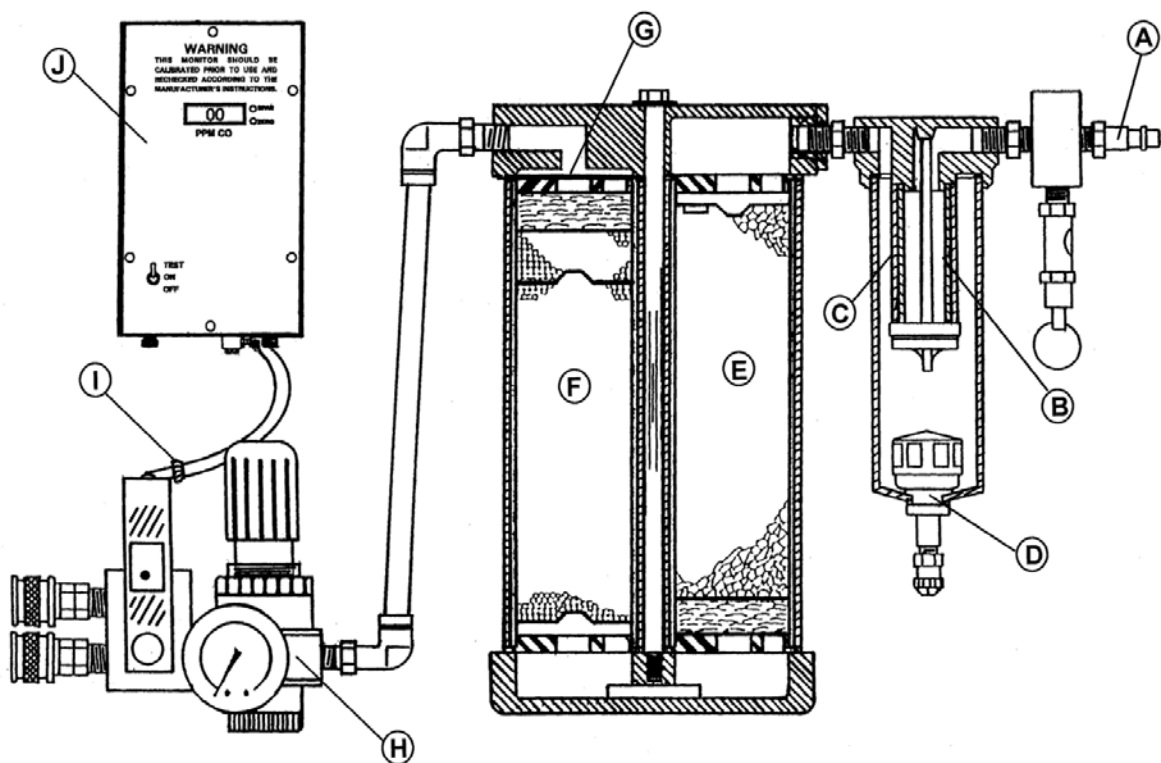

Figure 1

⚠ WARNING ⚠

The Blast-One Guardian APCMF5000 should not:

1. be used when the air entering the unit is oxygen deficient. The Guardian will not increase the oxygen content of oxygen deficient air.
2. be used in an 'Immediately Dangerous to Life and Health' atmosphere, (IDLH), unless it is used in conjunction with a back-up escape system or a supply air self-contained breathing apparatus (SCBA), where applicable.

INTRODUCTION

Blast-One strongly recommends that a complete safety program be established to ensure that the respiratory air is in compliance with all OSHA/CSA standards and other applicable laws regulating the use of supply air respiratory systems. Blast-One recommends that the air quality be tested upon installation and periodically re-tested to ensure that the minimum requirements for breathing air are maintained.

Blast-One will not assume any liability for accidents or personal injury resulting from the improper use of this equipment. Service on this equipment should only be performed by qualified personnel.

This system is to be used only by trained qualified personnel in accordance with a respiratory program as outlined in OSHA Regulation 29 CFR 1910.134(b).

CUSTOMER AIR SUPPLY

(Refer to Figure 2, on page 8)

1. **SUPPLY AIR LINE** Use minimum 3/8" I.D. hose or pipe to the unit.
2. **SUPPLY AIR LINE PRESSURE** Maximum air pressure at the unit's inlet should not exceed 150 psig. As a safety back-up, the Guardian incorporates a pressure relief valve rated at 150 psig.
3. **SUPPLY INLET AIR TEMPERATURE RANGE** 68°F to 150°F (20°C to 65°C).
4. **SUPPLY AIR CONDITIONING** May be required ahead of the unit to control:
 - a) Inlet air temperature.
 - b) Large volumes of oil/water from entering the unit.
A coarse oil/water extractor, (rated at 2 microns abs.), may be required if excessive oil/water conditions are present. Installation of the extractor should be located as close to the unit's inlet hook-up as possible.
5. **AVOID INSTALLING Guardian AFTER DESICCANT DRYER** – The desiccant dryer will produce extremely dry air, (4% R.H. or less). The fourth stage catalyst requires 30 - 90% R.H. in the supply air for the catalyst to work and remove carbon monoxide efficiently. The extremely dry air produced by a desiccant dryer will also cause worker discomfort, i.e. dry throat, etc.

INITIAL INSTALLATION AND START-UP

(Refer to Figure 2, on page 8)

Monitor

- 1. POWER MONITOR/CALIBRATE** – install the 9 volt batteries or external power source to the monitor. Switch the monitor on for a minimum five minutes to warm-up. After the warm-up period, check the monitor's audible/visual alarm system by pressing 'Off/On/Test' toggle switch up to 'TEST' position and hold. If the monitor is OK, the following will occur:
 - a) Red/Amber LED will be illuminated.
 - b) Green LED will blink initially and then come on solid.
 - c) Audible alarm will sound and the remote alarm jack will be energized.After testing, the monitor's calibration should be checked. Refer to this manual. Monitor should be calibrated prior to use and every two weeks thereafter for the first month. If the monitor is used on a non-continuous basis, calibrate prior to use.
- 2. CALIBRATION GAS REQUIREMENTS** – 'zero' gas (nitrogen, free of 'CO'), 'span' gas (50 to 150 ppm of 'CO' concentration in air). Calibration gas flow to monitor should be 1.0 scfh (472 cc/minute).
- 3. TEMPERATURE EXTREMES** – avoid extreme temperature changes. The monitor best performs at a temperature range of 32°F to 104°F (0°C to 40°C). Always calibrate the monitor after it has stabilized in the surrounding temperature where system is to be used.

Purification System

- 1. INSTALL AIR FITTINGS** - approved double-action air fittings are supplied standard with unit.
- 2. SUPPLY AIR QUALITY** - remove any large volumes of oil/water from supply air line prior to connecting the system.

Depending on supply air quality, an external coarse oil/water extractor (2 microns abs.) may be required if excessive oil/water conditions are present. Installation should be prior to the system and should extend the life of the system's filters. The system's prefilter will handle oil/water down to .75 microns abs. (D.O.P. @ 99.97% efficiency). DO NOT INSTALL THE GUARDIAN AFTER CONDITIONING EQUIPMENT THAT PRODUCES SUPPLY AIR WITH LESS THAN 10% R.H.
- 3. NEW FILTER SYSTEM CONDITIONING** - flow supply air through new filter sets for several minutes to condition.
- 4. RESPIRATOR/HOOD/HOSE ASSEMBLY HOOK-UP** - couple hose assemblies to the unit's outlet using appropriate fittings. Consult manufacturer's respirator manual for the proper air pressure requirements. The air should be dynamically flowing through respirator/hose assemblies when the air pressure is set. DO NOT EXCEED RESPIRATOR/HOSE ASSEMBLY MANUFACTURER'S REQUIREMENTS FOR OUTLET PRESSURE. PERSONAL INJURY COULD RESULT.
- 5. After pressurising system and setting regulator for proper air flow to respirator(s), adjust air sample metering valve's adjustment knob so the black floating ball is within the GREEN boxed area etched on valve body.**

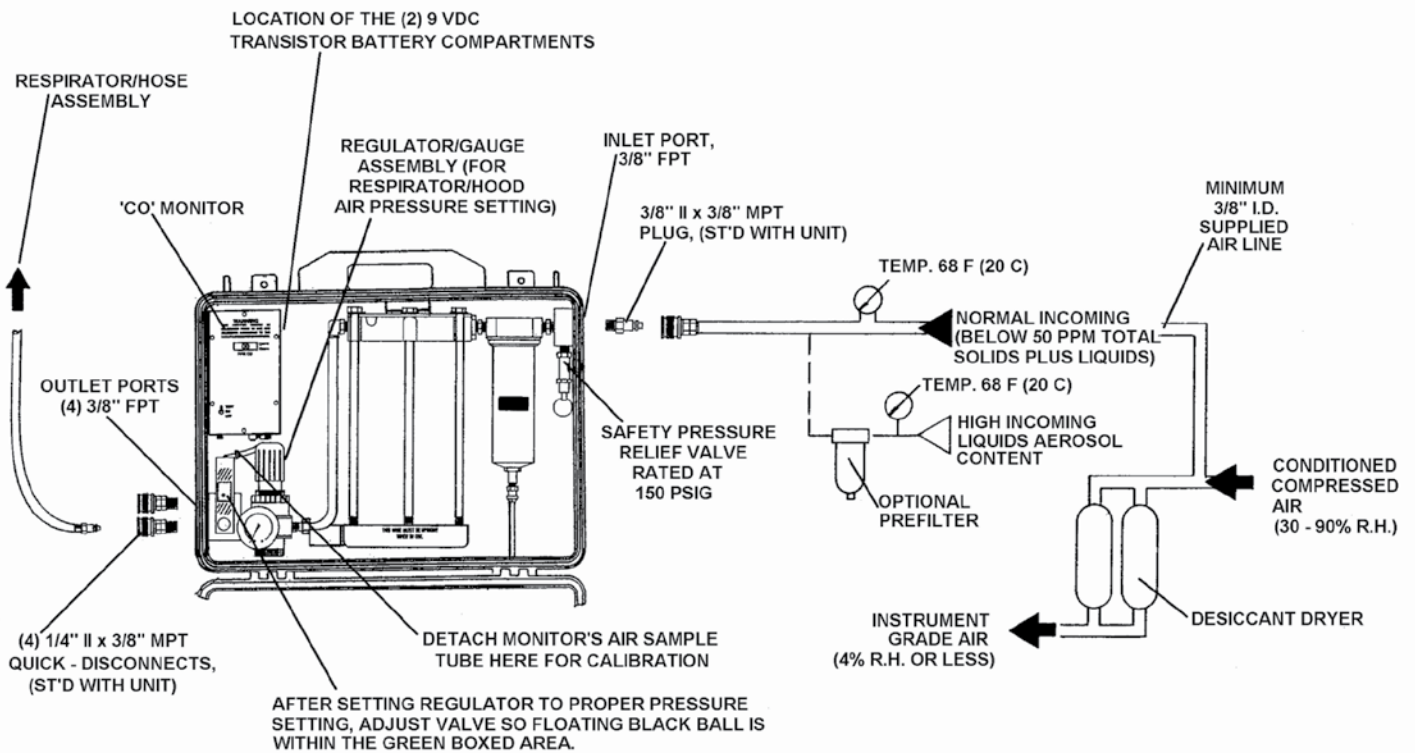

Figure 2

AIR SAMPLE TO MONITOR ADJUSTMENT

Air Sample Metering Valve Adjustment

(Refer to Figure 3)

1. Pressurize system and set regulator for proper air flow to respirator(s).
2. Adjust air sample metering valve so the black floating ball is within the GREEN BOXED area etched on valve body. Proper air sample is now being metered to the 'CO' monitor. Periodically check to be sure ball is floating in this area.

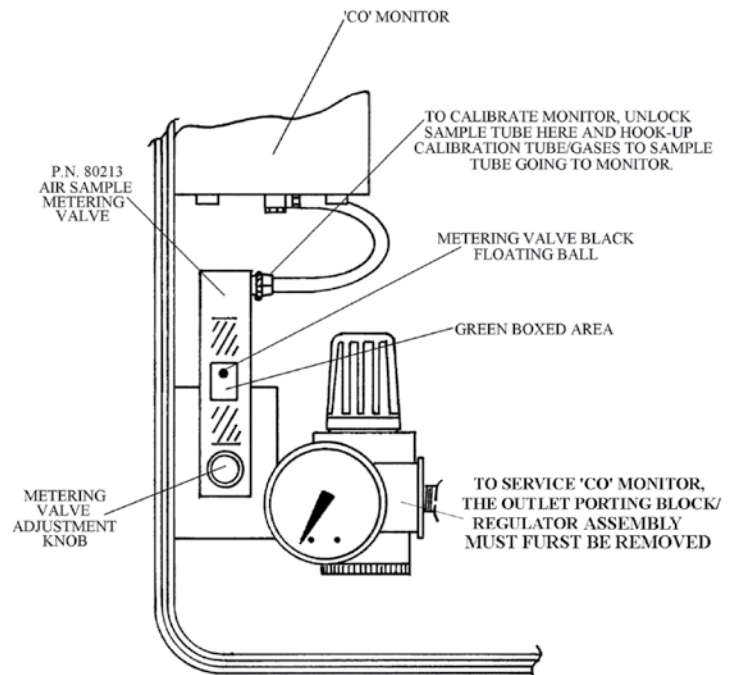

Figure 3

⚠ WARNING ⚠

SERIOUS INJURY could result if the AIR SAMPLE METERING VALVE is not properly adjusted. Proper sample air flow to 'CO' monitor is required for monitor to give correct 'CO' level readout.

GENERAL OPERATION AND MAINTENANCE

Monitor

1. **CALIBRATION** – The monitor utilizes an electrochemical sensor to measure the Carbon Monoxide content of the respirable air. If a problem has developed in the system, the monitor will alarm due to one or more of the following conditions:
 - a) Monitor is out of calibration. The monitor should be calibrated monthly if used continuously and prior to use if used on a non-continuous basis. Calibrate monitor as outlined in the this manual.
 - b) If the monitor can be and is calibrated, but the alarm still sounds, the filter cartridge life is exhausted. Replace all three filter cartridges as outlined in the FILTER REPLACEMENT INSTRUCTIONS, page 11.
 - c) If the monitor cannot be calibrated (i.e. the zero or span adjustments cannot be made within range of their respective potentiometer), the carbon monoxide sensor may require replacement. See manual for replacement instructions and other troubleshooting information.
 - d) If the monitor was calibrated in a surrounding temperature other than where the system was being used and the temperature difference was 36°F (20°C) or greater, the monitor may give a false alarm due to its characteristics. Always calibrate the monitor in the temperature conditions where the monitor is to be used in. The monitor best performs in a temperature range of 32°F to 104°F (0°C to 40°C).
2. **CALIBRATION GAS REQUIREMENTS** – ‘Zero’ gas (nitrogen, free of ‘CO’), ‘span’ gas (50 to 150 ppm of ‘CO’ concentration in air). Calibration gas flow to monitor should be 1.0 scfh (472 cc/minute).
3. **MONITOR ALARMS** - should be checked prior to use by pushing up toggle switch to ‘TEST’ position (refer to manual).
4. **POWER SUPPLY** - two 9 volt transistor-type batteries (unless optional power supply used). The batteries will power the monitor continuously for approximately 30 - 35 hours. When the batteries output falls below seven volts, the amber ‘Low Battery’ LED will come on, indicating the batteries require replacement. When installing the new batteries into the battery holders, review polarity position marked inside holders and install batteries accordingly.
5. **AIR SAMPLE FLOW** - flow of the air sample to the monitor should be checked periodically. Check that the black floating ball is within the GREEN BOXED area etched on the valve body when air is flowing to respirators.
6. **TEMPERATURE EXTREMES** – avoid extreme temperature changes. The monitor best performs at a temperature range of 32°F to 104°F (0°C to 40°C).
7. **MONITOR WARRANTY (INCLUDES ‘CO’ SENSOR)** – the monitor has one year warranty. All warranty work must be performed at factory.

PURIFICATION SYSTEM

- 1. SYSTEM FILTERS** – should last 320 hours on average, depending on the supply air quality. Filters should be replaced monthly unless the air quality conditions warrant more or less frequent replacement. NOTE: If the supply air entering the unit has high volumes of liquids in it, the filter set life may be greatly reduced. See CUSTOMER AIR SUPPLY, page 6, for corrective measures to take. Replace all three filter cartridges if:
 - a) The 'CO' Monitor alarms (fourth stage catalyst is used up).
 - b) The operator detects a petroleum smell and or taste in his purified air (third stage charcoal is used up).
- 2. NEWLY INSTALLED FILTER SET** – condition newly installed filters sets by purging supply air through the system for five minutes prior to use.
- 3. DORMANT PURIFICATION SYSTEM** – if the unit is not to be used for an extended period of time and is to be stored, check 3rd and 4th stage filters for presence of liquid/moisture. If moisture is present, dry the system and replace all filters. Also consider changing the filter set more frequently and or installing an OPTIONAL PREFILTER prior to system hook up. If the filters are dry, they can be left in the system.
- 4. FILTER SET SHELF LIFE** – the filters have an indefinite shelf life, but should be stored in a cool/dry area.

FILTER SET SERVICE INSTRUCTIONS

WARNING

Always turn off air supply and bleed air pressure before disassembling unit or **SERIOUS INJURY COULD RESULT.**

(Refer to Figure 4, on page 12)

Blast-One recommends replacing all three filter cartridges after one month of use unless conditions warrant more or less frequent replacement. To replace the filter cartridges in the Guardian follow these steps:

1. PREFILTER FIRST/SECOND DUAL STAGE ELEMENT REPLACEMENT

- a) First unlock tube locking collar and then pull drain tube **(1)** down through case. Then unscrew prefilter bowl assembly **(2)**, clean with a mild soap and water solution and blow dry with low pressure air.
- b) Remove dual stage element **(3)** by unscrewing end cap retaining nut **(4)**.
- c) Inspect the prefilter manifold **(5)** for dirt/contaminates and clean as required. Inspect O-Ring **(6)** for cuts, etc. and replace if required.
- d) Install new dual stage element and tighten end cap retaining nut. Be sure element is seated squarely on manifold boss and end cap.
- e) Apply light film of petroleum jelly on bowl's bevelled edge to provide good seal between bowl and O-Ring. **HAND TIGHTEN ONLY.**
- f) Guide drain tube back through hole in case bottom and lock into tube locking collar.
- g) Dispose of used dual stage element according to local, state and federal regulations.

2. THIRD/FOURTH STAGE CARTRIDGE REPLACEMENT

- a) Loosen bracket bolt **(7)** from bracket **(8)** (do not remove).
- b) Loosen the five manifold bolts **(9)** and remove the front two bolts. Now slide out the third **(10)** and fourth **(11)** stage aluminium tube assemblies.
- c) Remove the end cap **(12)** from third stage aluminium tube assembly and slide old third stage filter cartridge **(13)** out of aluminium tube. Clean aluminium tube in mild soap and water, dry and install new third stage filter cartridge. Be sure the flow direction arrow on third stage filter cartridge is pointing down. Remove end sealing label **(14)** and install new end cap.
- d) Follow same procedure for the fourth stage filter cartridge **(15)** replacement as in step (C). Be sure the flow direction arrow on fourth stage filter cartridge is pointing up. Also be sure to remove end sealing label before installing new end cap.
- e) Now slide the third and fourth stage aluminium tube assemblies back in place and install the front two manifold bolts.
- f) Tighten manifold bolts in sequence from centre outward to 100 inch-pounds (1.15 kg-m). Repeat sequence and re-torque bolts to 250 inch-pounds (2.88 kg-m).
- g) Tighten bracket bolt **(7)** against bracket **(8)**.
- h) Dispose of used cartridges according to local, state and federal regulations.

FILTER SET SERVICE INSTRUCTIONS

3. FINAL CHECK AND CALIBRATION

- a) Pressurize system and check for leaks.
- b) Flush system with compressed air for several minutes.
- c) Calibrate Carbon Monoxide monitor as outlined in this manual.

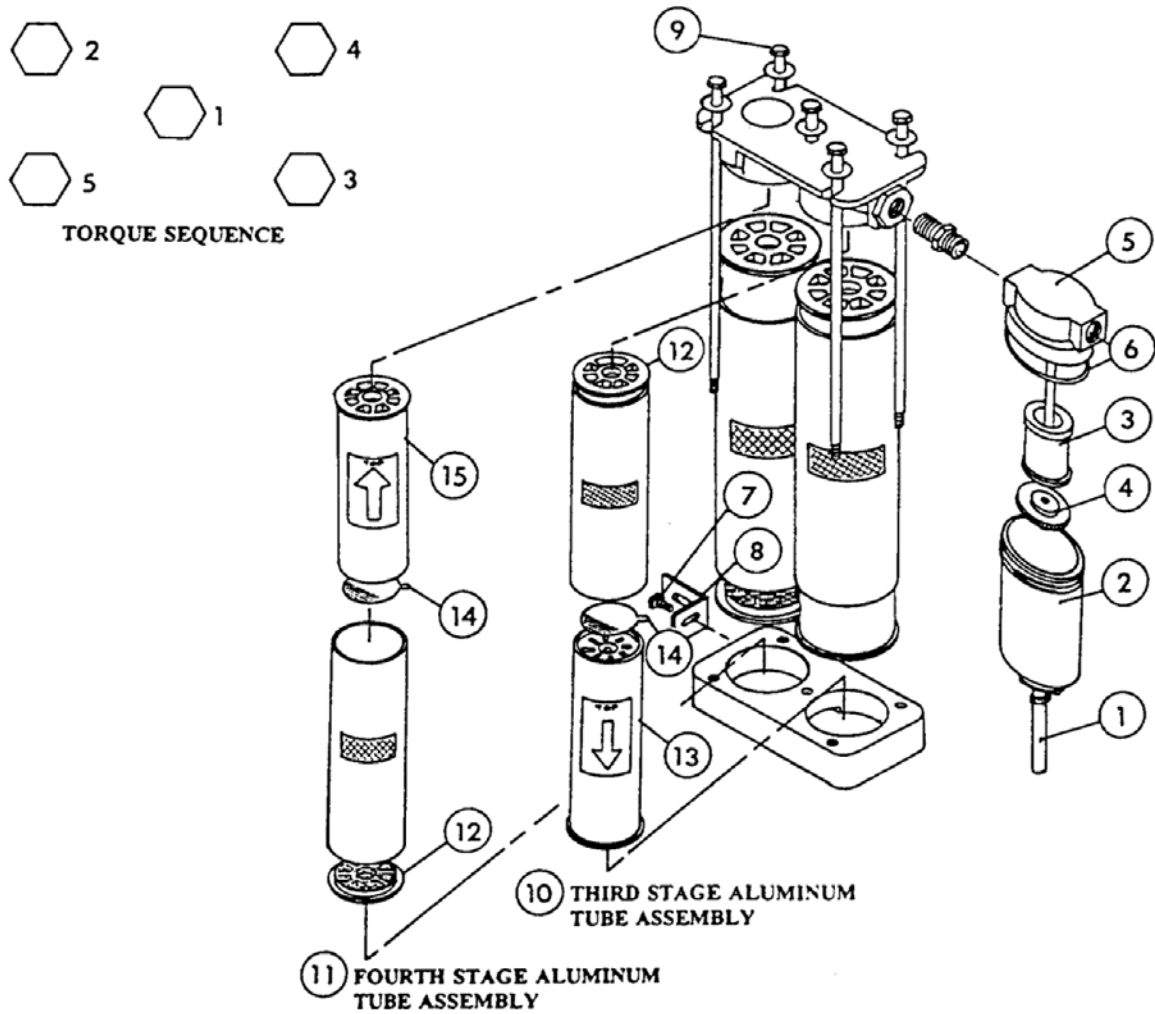

Figure 4

RECORD KEEPING

Record all periodical air quality checks, monitor calibration date, filter cartridge change intervals and any other service performed on the Blast-One Guardian on the pages following.

BLAST-ONE SHALL NOT BE LIABLE FOR ANY INJURY, LOSS OR DAMAGE, (DIRECT OR CONSEQUENTIAL), ARISING OUT OF THE USE OF OR THE INABILITY TO USE THIS PRODUCT, BEYOND THE REPLACEMENT OF DEFECTIVE MATERIALS OR WORKMANSHIP. USER OF SUPPLY AIR RESPIRATORS SHOULD EVALUATE THEIR OWN PARTICULAR APPLICATION AND PERFORM THEIR OWN TESTS FOR AIR QUALITY TO DETERMINE THE SUITABILITY FOR USE OF THIS PRODUCT.

For further information, or questions about service or maintenance care of this unit, contact your local distributor or Blast-One.

PERFORMANCE CURVES

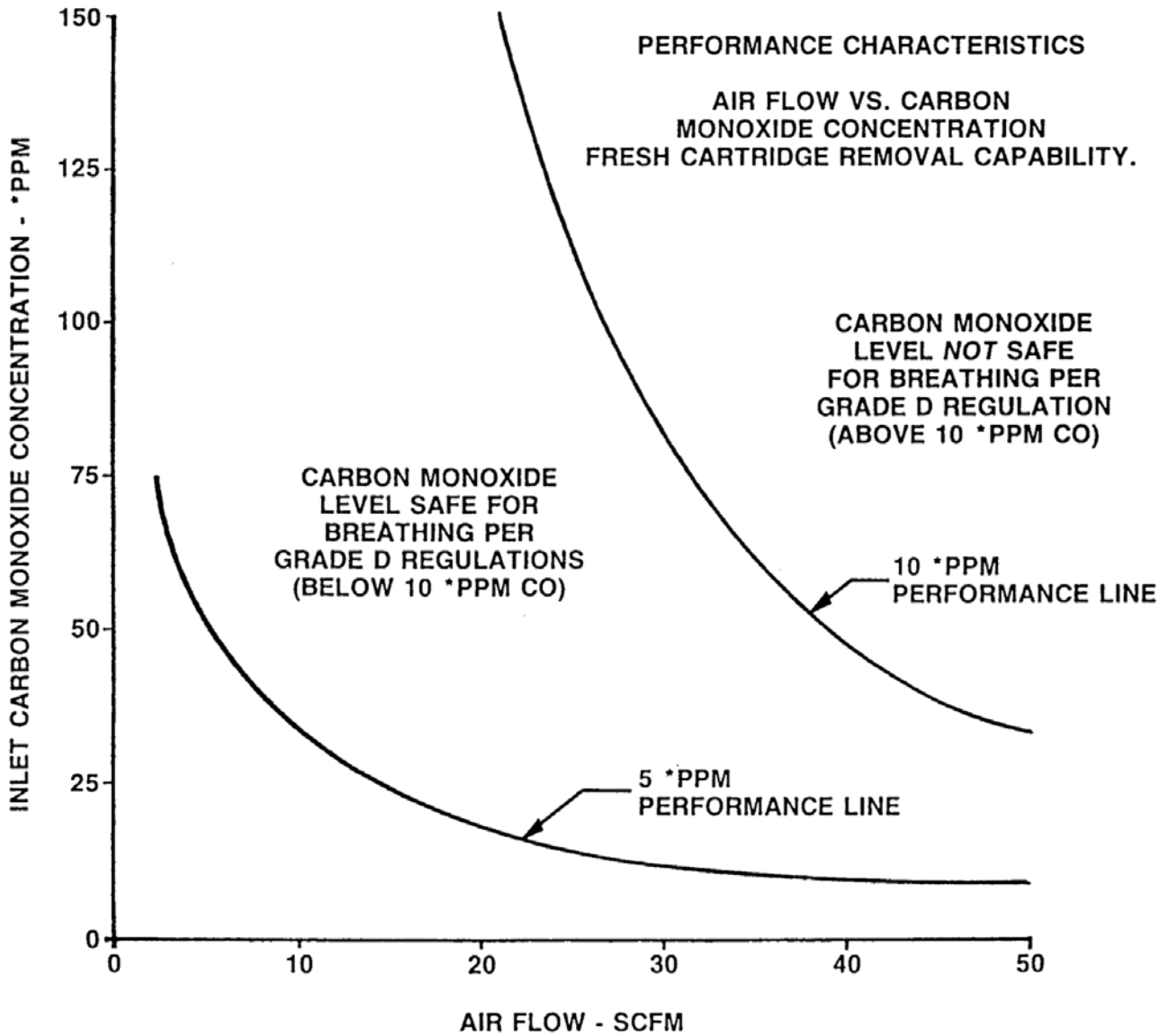

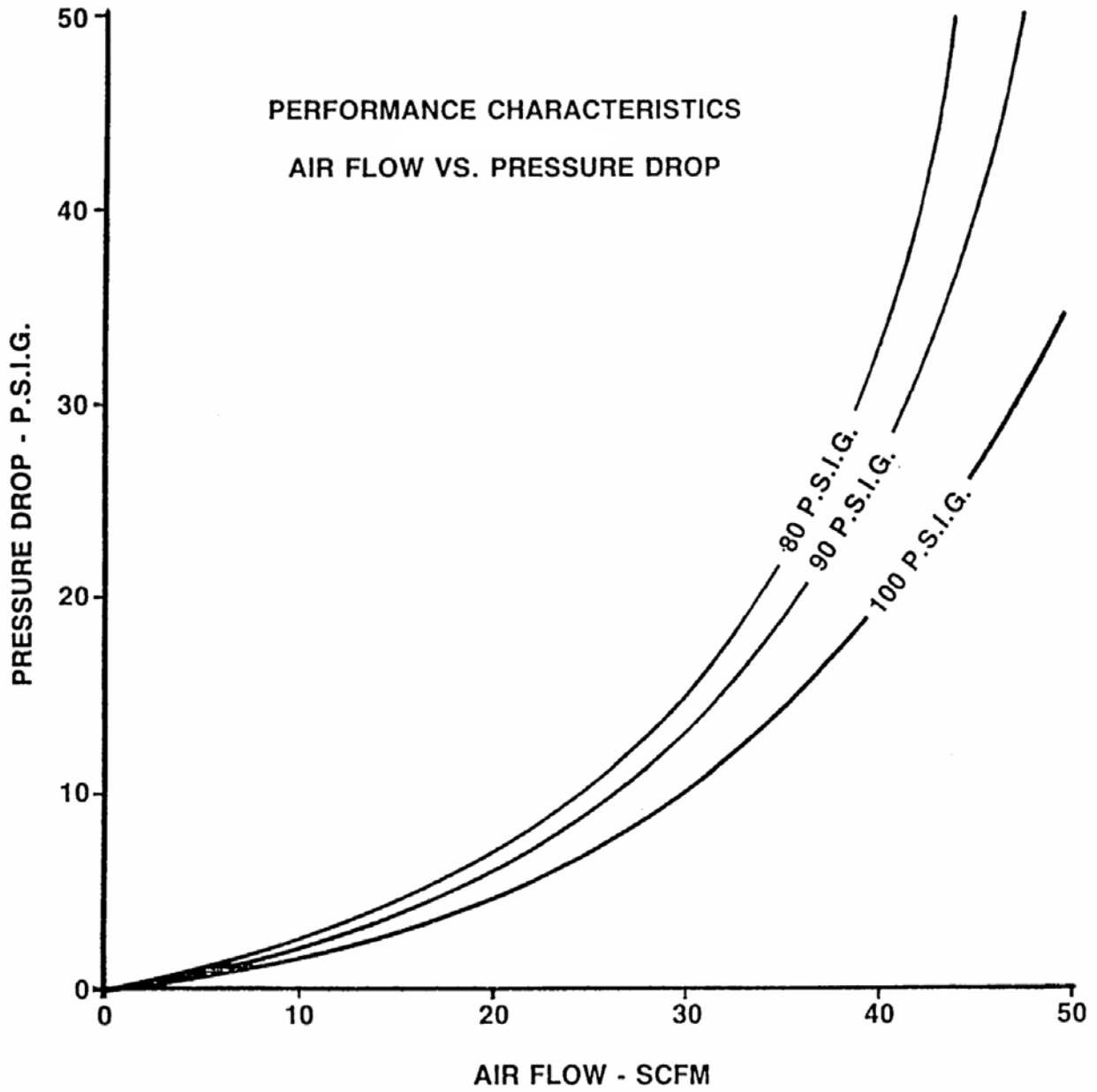

REPLACEMENT PARTS

ITEM	DESCRIPTION	QTY	PART NO.
1	Orange Case	1	AP CMF80143
2	Black Porting Block	1	AP CMF80008
3	Pressure Relief Valve	1	AP CMF80014
4	Hex Nipple 3/8"	3	AP CMFS608-005
5	Prefilter 50 scfm	1	AP CMF5000PF
6	Tube Locking Collar	3	AP CMF80051
7	Drain tube	1	AP CMFS710-005
8	Black Base	1	AP CMF80001
9	Aluminium Tube Third Stage	1	AP CMF80005
10	Aluminium Tube Fourth Stage	1	AP CMF80005
11	Base Bracket	1	AP CMF80114
12	Black Manifold	1	AP CMF80078
13	'CO' Monitor	1	AP CMF80127
14	Manifold Bracket	1	AP CMF80009
15	Bracket Bolts	3	AP CMFS006-148
16	Manifold Bolts	5	AP CMFS011-040
17	Manifold Washers	5	AP CMF12021
18	Tubing St. Elbow	2	AP CMF80116
19	Tubing	1	AP CMF80117B
20	Regulator	1	AP CMF80080
21	Black Outlet Block	1	AP CMF80047
22	Hex Pipe Plug 1/8"	3	AP CMFS687-001
23	Close Nipple 1/8"	1	AP CMFS603-001
24	Sampling Metering Valve	1	AP CMF80213
25	Sampling Hose Connector	1	AP CMF80261
26	Pressure Gauge 0 - 160	1	APCMF80076

ITEM	DESCRIPTION	PART NO.
-	Guardian Breathing Air Station Complete	AP CMF5000
-	Guardian Calibration Kit	AP CMF5500
-	Guardian Replacement Filter Kit	AP CMF5550

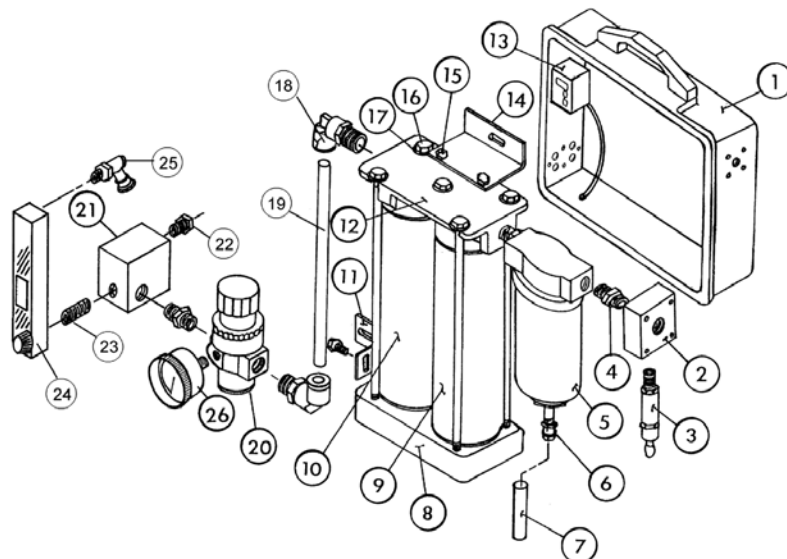



BLASTONE

BLASTONE INTERNATIONAL (AUST) PTY LTD

57 Alexandra Place Murarrie
Queensland 4172 Australia

PO Box 3385 Tingalpa DC
Queensland 4172 Australia

Toll Free 1800 190 190
Tel (07) 3329 5000
Fax (07) 3329 5066
Email sales.au@blastone.com
www.BlastOne.com

AUSTRALIAN OFFICES

Adelaide | Brisbane | Darwin | Mackay |
Melbourne | Perth | Sydney

BLASTONE INTERNATIONAL

4510 Bridgeway Avenue
Columbus Ohio 43219 USA

Toll Free 800 999 1881
Tel (614) 476 3000
Fax (614) 476 3002
Email sales@blastone.com
www.BlastOne.com

NORTH AMERICAN OFFICES

Chicago | Columbus | Los Angeles |
Minneapolis