



**SPONGE-JET<sup>®</sup>**

**170-SJ Feed Unit<sup>™</sup>**

**470-SJ Feed Unit<sup>™</sup>**

**USER MANUAL**



Sponge-Jet, Inc. (USA)  
14 Patterson Lane  
Newington, NH 03801

+1-603-610-7950  
[www.spongejet.com](http://www.spongejet.com)

---

# CONTENTS

<b>1.0</b>	<b>Basic Components</b>	<b>0</b>
<b>2.0</b>	<b>Safety Checklist</b>	<b>6</b>
<b>3.0</b>	<b>Requirements</b>	<b>8</b>
<b>4.0</b>	<b>Operation</b>	<b>11</b>
<b>5.0</b>	<b>Maintenance</b>	<b>18</b>
<b>6.0</b>	<b>Troubleshooting</b>	<b>20</b>
	<b>Notes</b>	<b>30</b>
	<b>Addendum</b>	

---

**IMPORTANT NOTE:** While parts, systems, components, operational procedures may be the same between equipment models, the images provided in this manual may vary from model to model.

This manual represents the following models and their approximate working capacity:

**Model:** 170-SJ

**Working Capacity:** 170 liters

**Model:** 470-SJ

**Working Capacity:** 470 liters

English Language is Original Instructions.

Translated from Original Instructions.

# 1.0

# BASIC COMPONENTS

- 1 **Certified Lifting Point (4x)**
- 2 **Hopper Lid (optional)**
- 3 **Supply Line Connection**
- 4 **Hopper**
- 5 **Twinline Quick Connect Fittings**
- 6 **Main Air Ball Valve**
- 7 **Pressure Vessel**
- 8 **Secondary Water Separator**
- 9 **Blast Hose Connection**
- 10 **Air Motor**
- 11 **Gasket**
- 12 **Handhole Cover**
- 13 **Crab Assembly**

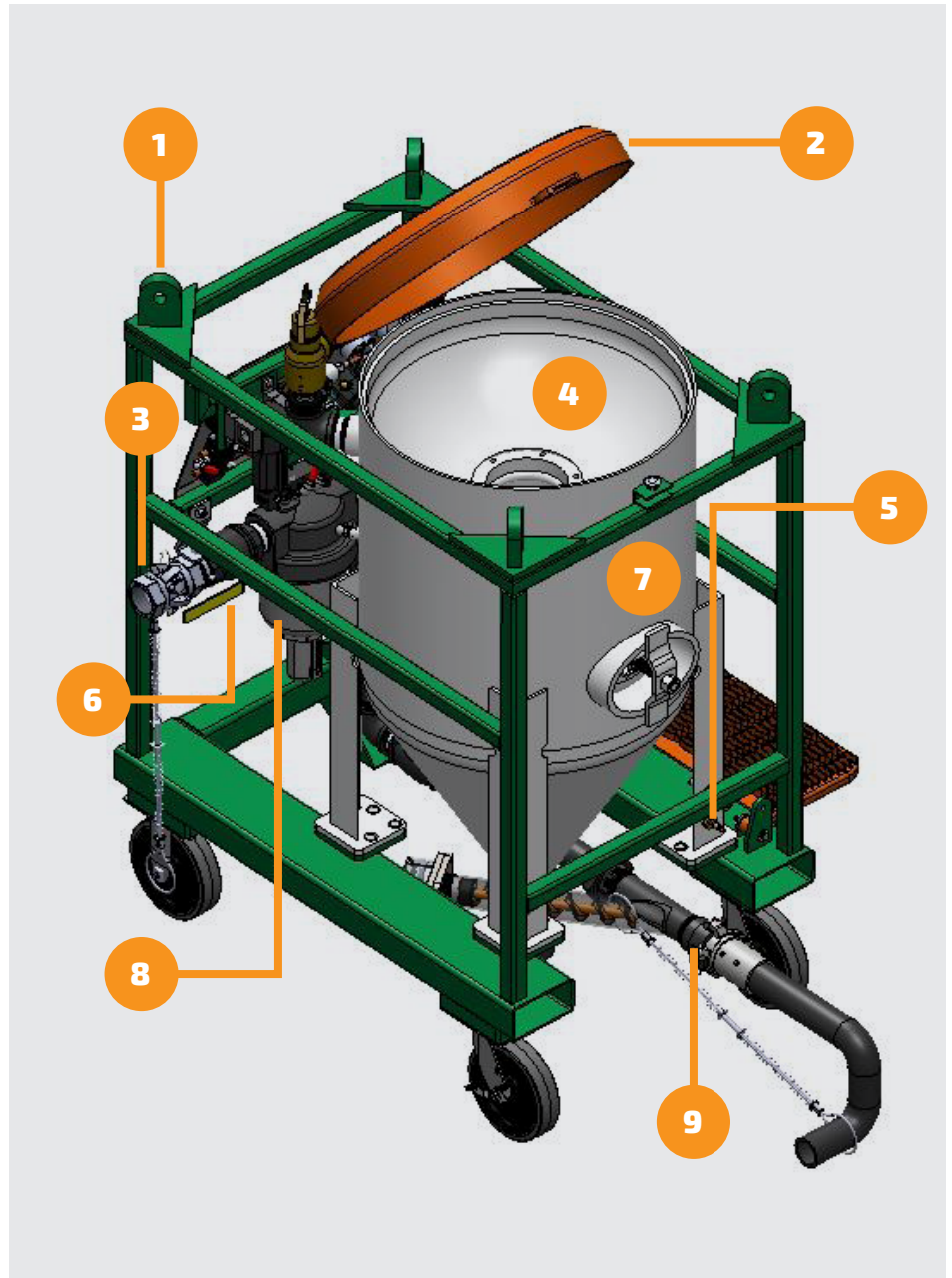
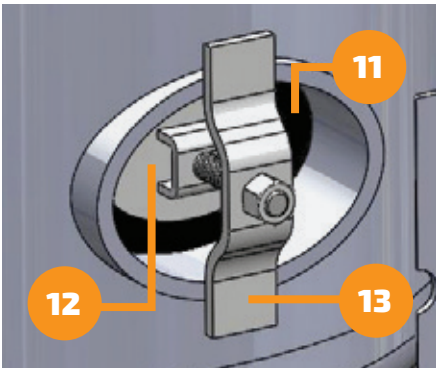
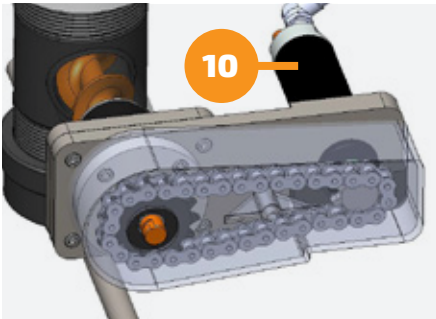

- 14 Safety Valve
- 15 Control Panel
- 16 Exhaust Valve
- 17 Control Panel
- Moisture Separator
- 18 Exhaust Muffler
- 19 Utility Step
- 20 On/Off Blast Pressure Regulator
- 21 Air Motor Moisture Separator
- 22 Air Motor Lubricator
- 23 Pop-up
- 24 Actuator Tree and Chain
- 25 Actuator Control Line
- 26 Media Actuator
- 27 Choke Valve
- 28 Air Motor
- 29 Auger Chain Guard
- 30 Manual Rotation Knob
- 31 Clean Out Trap

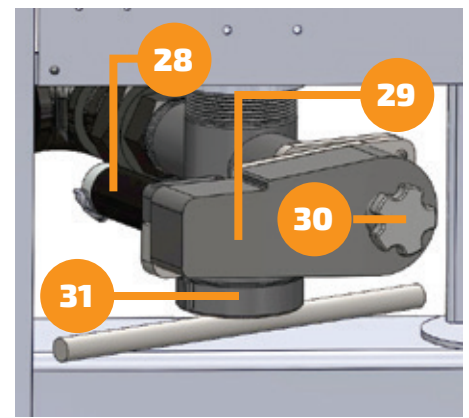
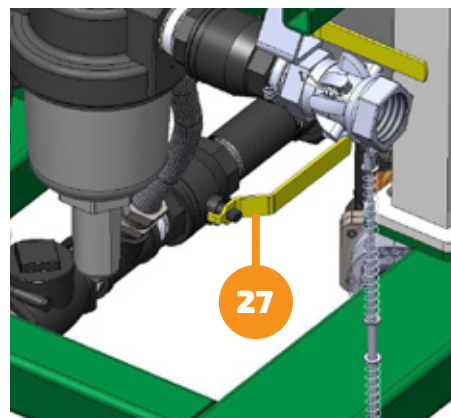
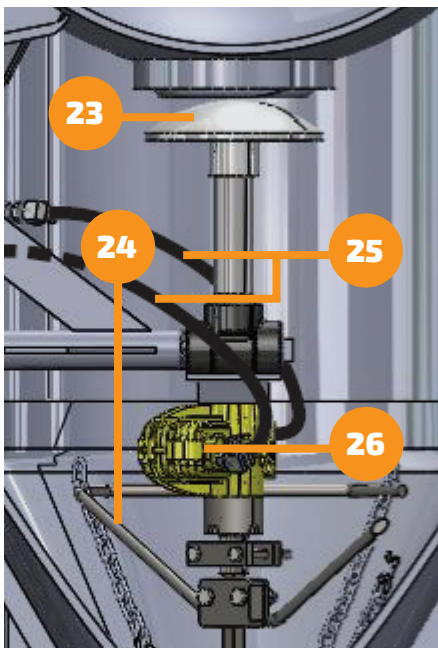
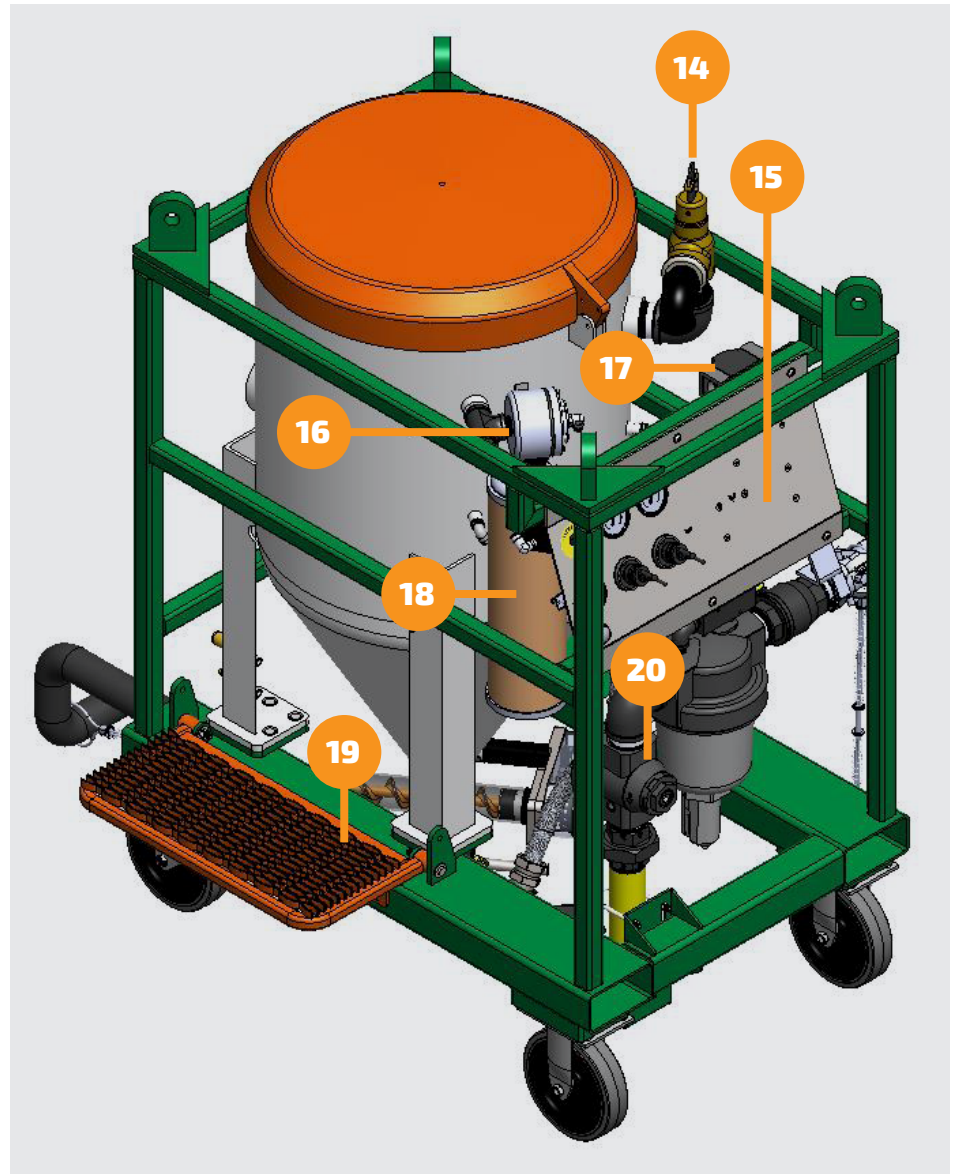



- 32 Emergency Stop Button
- 33 Blast Pressure Gauge
- 34 Media Feed Gauge
- 35 Blast Pressure Adjustment
- 36 Media Feed Adjustment
- 37 Line Pressure Gauge
- 38 Actuation Rate Indicator Eye
- 39 Blast Hose
- 40 Nozzle Holder
- 41 Nozzle
- 42 Twinline
- 43 Twinline Connection
- 44 Deadman Handle

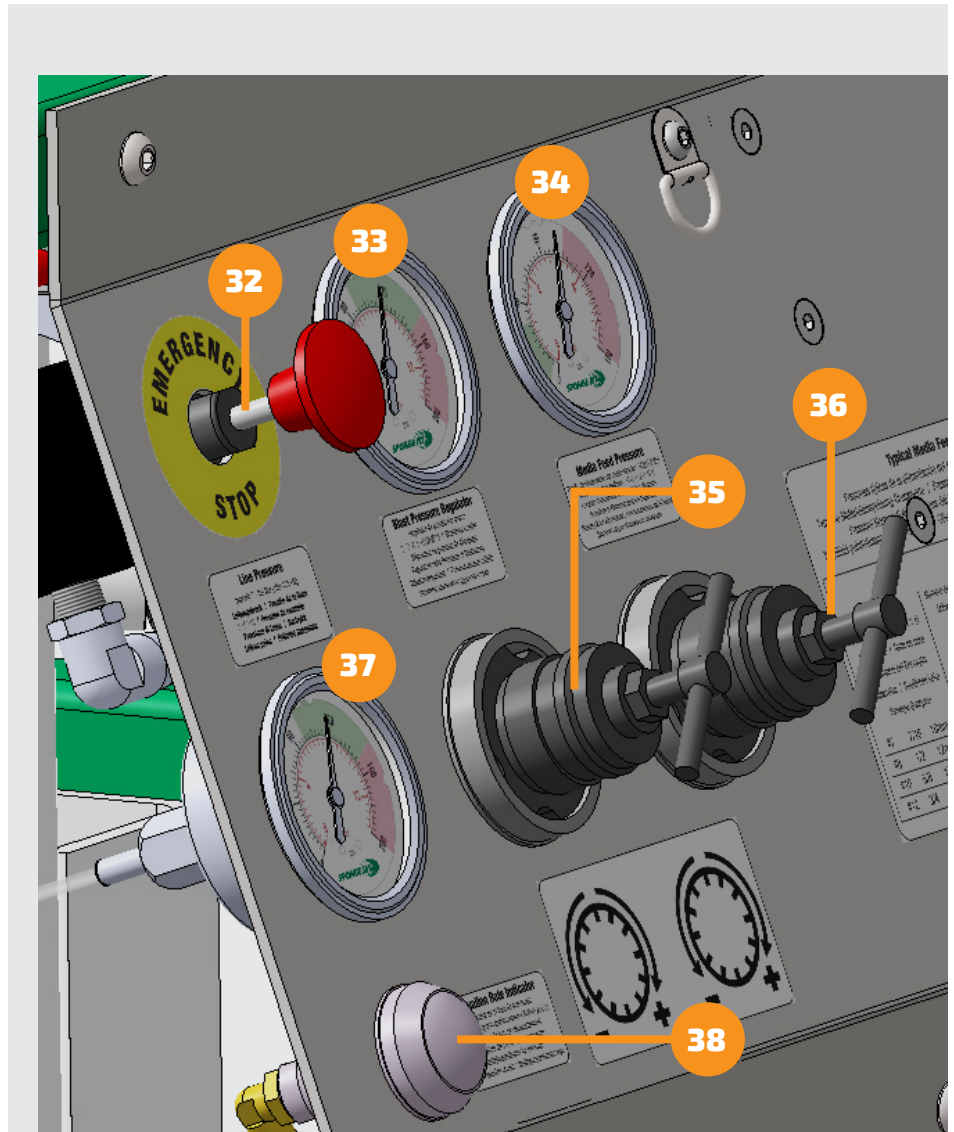

# 2.0

# SAFETY CHECKLIST

**The safety of you and others is extremely important.**

There are important safety messages in this manual and on your product. Always read and obey safety messages.



This is a safety alert symbol. This symbol alerts to hazards that can injure or kill you and/or others. The safety alert symbol and words like "Caution" and "Danger" precede all safety messages. These words mean:

**WARNING:** Indicates a hazardous situation which, if not avoided, could result in death or serious injury.

**CAUTION:** Indicates a hazardous situation, which, if not avoided, could result in minor or moderate injury.

**Survey environment for hazards; read manual and instructions before operating and follow ALL safety practices in accordance with ALL applicable local regulations.**

**ENSURE CAPACITY OF THE CUSTOMER-INSTALLED OVER-PRESSURE RELIEF VALVE EQUALS OR EXCEEDS CAPACITY OF THE COMPRESSED AIR SUPPLY.**

**FACTORY-SUPPLIED OVERPRESSURE RELIEF VALVE IS RATED  $\leq 45M^3/MIN$  (1600 SCFM). CONFIRM INSTALLED OVERPRESSURE RELIEF VALVE ON UNIT IS SUITABLE FOR THE RATING OF THE COMPRESSED AIR SUPPLY.**



**Location and usage of Emergency Stop Button should be understood before operation. Pushing in the Emergency Stop Button stops operation; Pulling it out allows for operation. DO NOT pull Emergency Stop Button and press Deadman until ALL operators are fully prepared to blast and nozzle(s) are under operator control.**

This Unit is a pressurized system. Only trained operators should adjust, maintain and repair it. Visit [www.spongejet.com](http://www.spongejet.com) for information on training.

**Inbound pressure should never exceed the listed Maximum Working Pressure on the data plate.** To prevent electrostatic buildup and possible electric discharge, the unit and work piece must be properly grounded/bonded.

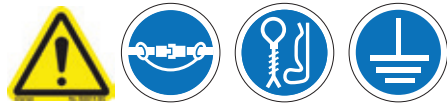

### WARNING

**Secure ALL safety restraints. Whip-check, safety pins, wire, grounding straps and hose couplings must be properly secured before operating. Failure to do so may result in serious injury or death.**



### WARNING

**Eye, hearing and respiratory personal protective equipment required for operators and others in close proximity to blasting. Failure to do so may result in serious injury.**



### WARNING

**Sudden media discharge and loud noise. Keep hands and face free from area. ALWAYS use proper respiratory, hearing and eye protection equipment.**

**The operator and anyone within 1m (3ft) of the nozzle can be exposed to sound emission in excess of 120 dB(A).**

**Never point Blast Nozzle towards yourself or others.**



**WARNING**

**ONLY** use Sponge-Jet approved positive-feed Deadman control handles. **DO NOT** reverse twinlines. Failure to comply will override safety controls, cause unintentional start-up and unreliable shutdown—which may lead to serious injury or death.

**Inspect ALL equipment prior to each shift.**

**Never** operate Unit with any worn or malfunctioning components.

**All pneumatic lines** should be inspected for holes, wear and proper fit.

Safety pins (wire) and whip-checks should be fitted at all Air Supply Hose and **Blast Hose** couplings to prevent accidental disconnection.

**Never** weld or make modifications to pressure vessel, as this will void certifications.

Do not operate without **Auger Chain Guard** in place.



**CAUTION**

**Crush hazard. Lock wheels before operating. Unit may roll, resulting in personal injury.**



**WARNING**

**Hand-hole MUST be securely fastened. Improper seal may result in serious injury.**



**WARNING**

**Do not operate with guards removed. Moving parts may cut, pinch, or crush. Keep clear of moving parts.**



**WARNING**

**Pressurized system. Release air pressure before servicing. Failure to comply may result in serious injury.**

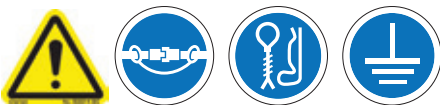

**WARNING**

**Secure ALL safety restraints. Whip-check, safety pins, wire, grounding straps and hose couplings must be properly secured before operating. Failure to do so may result in serious injury or death.**

Keep hands clear from Pop-up when Deadman is first being pressed.



**WARNING**

**Pinch point. Moving unit may cut, pinch or cause dismemberment; keep clear of moving parts.**

# 3.0

# REQUIREMENTS

## 3.1

### Air Supply/Compressor

Clean, dry, compressed air must be supplied in adequate volume and pressure to accommodate nozzle size at the desired blast pressure.

**Highest rated pressure for models in this manual is 10.3bar (150psi).**

*\*Always check vessel rating located on Unit's data-plate.*

**NOTE:** High-humidity environments require additional moisture separators.



### (METRIC) M3/MIN REQUIREMENTS

Nozzle Size		4.1bar	4.8bar	5.5bar	6.2bar	6.9bar	8.3bar	9.7bar
<b>No. 6</b> <b>9.5mm</b>	Nozzle	3.6	4.0	4.6	4.9	5.5	6.2	7.1
	Feed Unit	1.1	1.1	1.1	1.1	1.1	1.1	1.1
	Reserve	0.9	1.0	1.1	1.2	1.3	1.5	1.6
	<b>Total</b>	<b>5.6</b>	<b>6.2</b>	<b>6.8</b>	<b>7.2</b>	<b>8.0</b>	<b>8.8</b>	<b>9.8</b>
<b>No. 7</b> <b>11mm</b>	Nozzle	4.8	5.5	6.1	6.8	7.2	8.5	9.8
	Feed Unit	1.1	1.1	1.1	1.1	1.1	1.1	1.1
	Reserve	1.2	1.3	1.5	1.6	1.7	1.9	2.2
	<b>Total</b>	<b>7.1</b>	<b>7.9</b>	<b>8.7</b>	<b>9.5</b>	<b>10.0</b>	<b>11.5</b>	<b>13.1</b>
<b>No. 8</b> <b>12.5mm</b>	Nozzle	6.3	7.1	7.9	8.7	9.6	11.1	12.7
	Feed Unit	1.1	1.1	1.1	1.1	1.1	1.1	1.1
	Reserve	1.5	1.7	1.8	2.0	2.1	2.4	2.8
	<b>Total</b>	<b>9.0</b>	<b>9.9</b>	<b>10.9</b>	<b>11.9</b>	<b>12.8</b>	<b>14.7</b>	<b>16.6</b>
<b>No. 10</b> <b>15mm</b>	Nozzle	10.1	11.4	12.8	14.3	15.5	17.3	19.8
	Feed Unit	1.1	1.1	1.1	1.1	1.1	1.1	1.1
	Reserve	2.2	2.5	2.8	3.1	3.3	3.7	4.2
	<b>Total</b>	<b>13.4</b>	<b>15.1</b>	<b>16.7</b>	<b>18.5</b>	<b>20.0</b>	<b>22.1</b>	<b>25.1</b>
<b>No. 12</b> <b>18mm</b>	Nozzle	14.2	16.3	18.4	19.8	22.6	28.6	32.8
	Feed Unit	1.1	1.1	1.1	1.1	1.1	1.1	1.1
	Reserve	3.1	3.5	3.9	4.2	4.8	5.9	6.8
	<b>Total</b>	<b>18.3</b>	<b>20.9</b>	<b>23.4</b>	<b>25.1</b>	<b>28.5</b>	<b>35.7</b>	<b>40.7</b>



## (IMPERIAL) CFM REQUIREMENTS

Nozzle Size		60psi	70psi	80psi	90psi	100psi	120psi	140psi
<b>No. 6</b> <b>3/8in</b>	Nozzle	126	143	161	173	196	220	253
	Feed Unit	40	40	40	40	40	40	40
	Reserve	33	37	40	43	47	52	59
	<b>Total</b>	<b>199</b>	<b>220</b>	<b>241</b>	<b>256</b>	<b>283</b>	<b>312</b>	<b>352</b>
<b>No. 7</b> <b>7/16in</b>	Nozzle	170	194	217	240	254	300	344
	Feed Unit	40	40	40	40	40	40	40
	Reserve	42	47	51	56	59	68	77
	<b>Total</b>	<b>252</b>	<b>281</b>	<b>308</b>	<b>336</b>	<b>353</b>	<b>408</b>	<b>461</b>
<b>No. 8</b> <b>1/2in</b>	Nozzle	224	252	280	309	338	392	450
	Feed Unit	40	40	40	40	40	40	40
	Reserve	53	58	64	70	76	86	98
	<b>Total</b>	<b>317</b>	<b>350</b>	<b>384</b>	<b>419</b>	<b>454</b>	<b>518</b>	<b>588</b>
<b>No. 10</b> <b>5/8in</b>	Nozzle	356	404	452	504	548	611	701
	Feed Unit	40	40	40	40	40	40	40
	Reserve	79	89	98	109	118	130	148
	<b>Total</b>	<b>475</b>	<b>533</b>	<b>590</b>	<b>653</b>	<b>706</b>	<b>781</b>	<b>889</b>
<b>No. 12</b> <b>3/4in</b>	Nozzle	500	575	650	700	800	1,010	1,159
	Feed Unit	40	40	40	40	40	40	40
	Reserve	108	123	138	148	168	210	240
	<b>Total</b>	<b>648</b>	<b>738</b>	<b>828</b>	<b>888</b>	<b>1,008</b>	<b>1,260</b>	<b>1,439</b>

## 3.2

### Air Supply Requirements

This Unit uses a 50mm (2in) standard pipe typically fit with a 50mm (2in) universal 4-lug coupling.

Larger hoses decrease pressure loss.

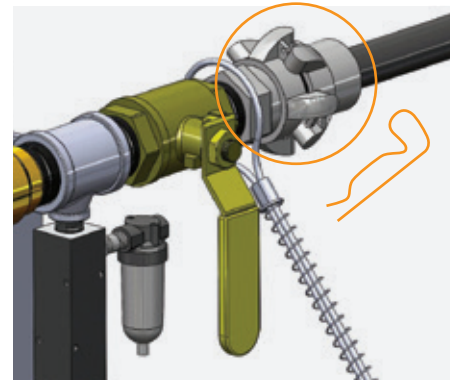

Nozzle	Orifice	Recommended Air Line I.D.
#6	9.5mm (3/8in)	50mm (2in)
#7	11mm (7/16in)	50mm (2in)
#8	12.5mm (1/2in)	76mm (3in)
#10	16mm (5/8in)	76mm (3in)
#12	19mm (3/4in)	76mm (3in)

---

## 3.3

### Blast Hoses

Extensions up to 30m (100ft) should have minimum 38mm (1.5in) I.D.

Extensions over 30m (100ft) should have minimum 50mm (2.0in) I.D. Blast Hose Extension. Larger hoses decrease pressure loss.

---

## 3.4

### Operating Temperature

Operating temperature range is  
0°C (32°F) to 50°C (120°F).

**NOTE:** Ice build-up from moisture may require thawing prior to operation.

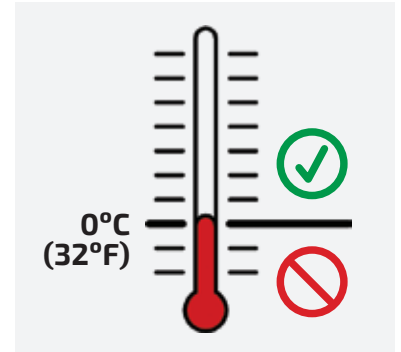

---

## 3.5

### Containment

Sponge-Jet Sponge Media™ must be contained to be efficiently recycled. Use plastic sheeting or mesh. Projects involving hazardous materials, high wind load or other challenging conditions may require more complex containment and negative air dust collection.

**NOTE:** Pre-cleaning the blast area can minimize dust and debris which can also cause equipment malfunctions.

**Always follow local, state and federal guidelines concerning proper containment, ventilation and monitoring procedures.**



#### **WARNING**

**Eye, hearing and respiratory personal protective equipment required for operators and others in close proximity to blasting. Failure to do so may result in serious injury.**

# 4.0

# OPERATION

This equipment is designed to be operated in a manner consistent only with instructions contained in this manual.

## Before Feed Unit Pressurization and Operation

Verify the **Emergency Stop Button** is pressed.



### CAUTION

Crush hazard. Lock wheels before operating. Unit may roll, resulting in personal injury.

All pneumatic lines should be inspected for holes, wear and proper fit.

Safety pins (wire) and whip-checks should be fitted at all Air Supply Hose and Blast Hose couplings to prevent accidental disconnection.



### WARNING

Hand-hole **MUST** be securely fastened. Improper seal may result in serious injury.

Do not operate without **Auger Chain Guard** in place.



### WARNING

Do not operate with guards removed. Moving parts may cut, pinch, or crush. Keep clear of moving parts.



### WARNING

Pressurized system. Release air pressure before servicing. Failure to comply may result in serious injury.

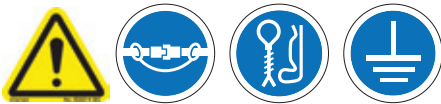

### WARNING

Secure ALL safety restraints. Whip-check, safety pins, wire, grounding straps and hose couplings must be properly secured before operating. Failure to do so may result in serious injury or death.

Keep hands clear from Pop-up when Deadman is first being pressed.



### WARNING

Pinch point. Moving unit may cut, pinch or cause dismemberment, keep clear of moving parts.



### WARNING

Eye, hearing and respiratory personal protective equipment required for operators and others in close proximity to blasting. Failure to do so may result in serious injury.

## 4.1

# Operation of Feed Unit

Inspect all **Blast Hose** and connections. Repair or replace worn or damaged components. Ensure all couplings are equipped with coupling gaskets, safety pins and whip-checks. Confirm all are properly installed.

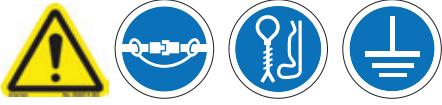

### WARNING

Secure ALL safety restraints. Whip-check, safety wire, grounding straps and hose couplings must be properly secured before operating. Failure to do so may result in serious injury or death.

Connect compressor to **Supply Line Connection** and secure safety pins and whip-check.

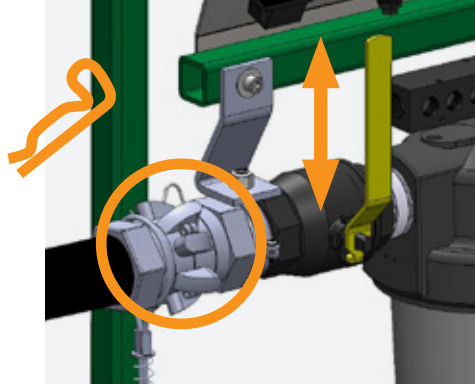

Attach **Handhole Cover** with gasket.

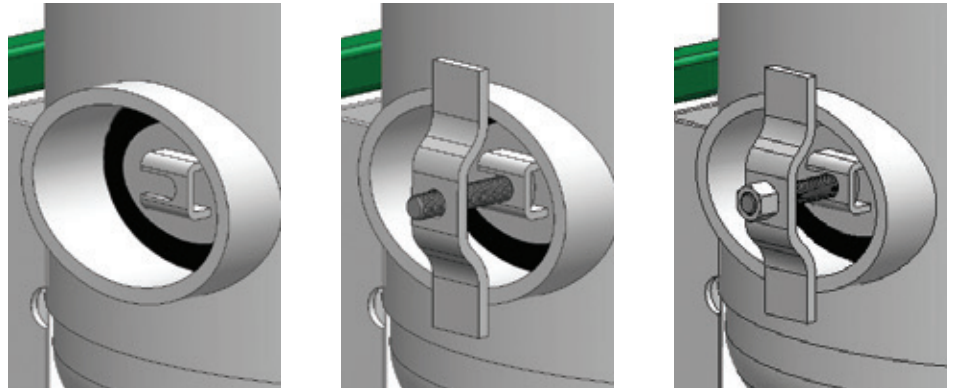

Connect **Blast Hose** and secure with twisted wire.

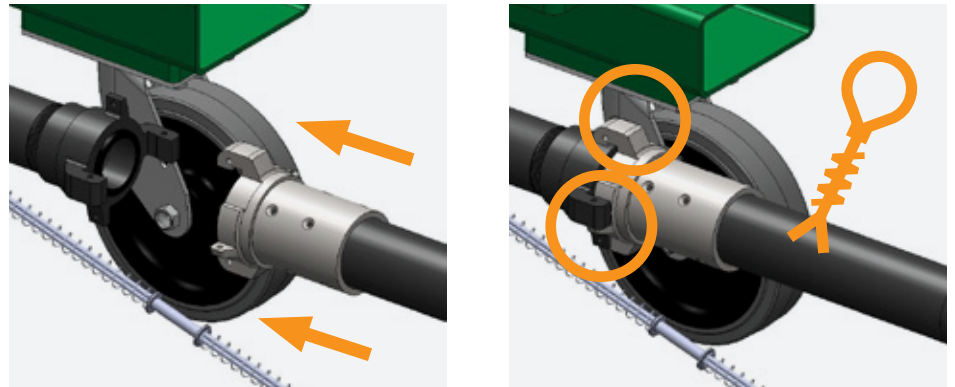

Confirm **Choke Valve** is open.

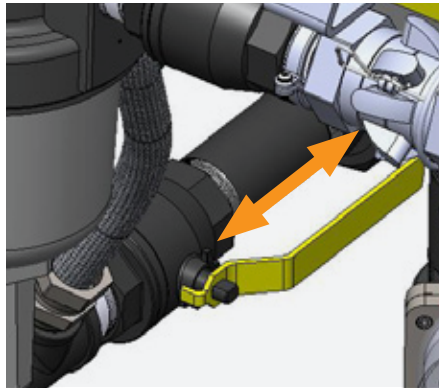

Connect Return and Supply **Twinline Quick Connect Fittings**.

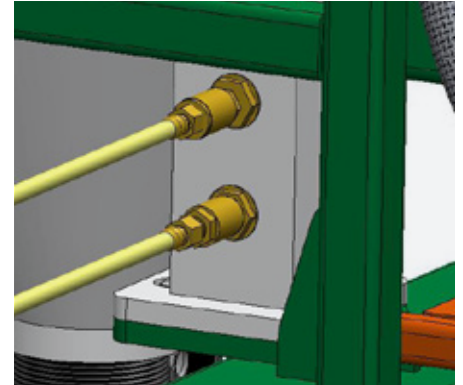
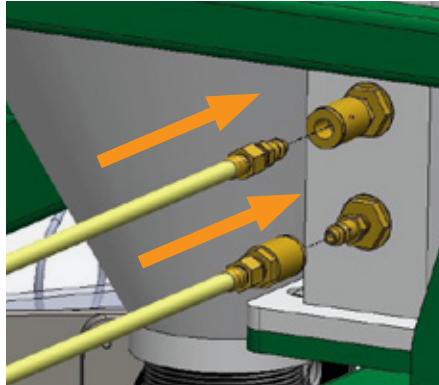

Fill Feed Unit through **Hopper**.



**WARNING**

Pinch point. Moving part may cut, pinch or cause dismemberment, keep clear of moving pop-up.



**WARNING**

Eye, hearing and respiratory personal protective equipment required for operators and others in close proximity to blasting. Failure to do so may result in serious injury.



Check **Main Air Ball Valve** is closed, then charge supply line.

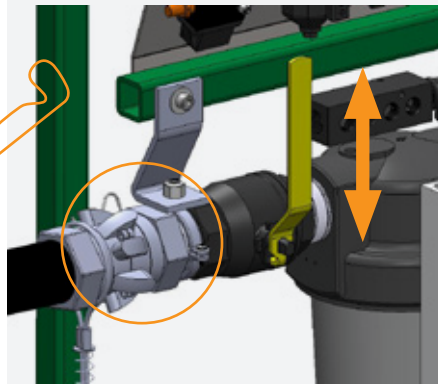

Open **Main Air Ball Valve**.

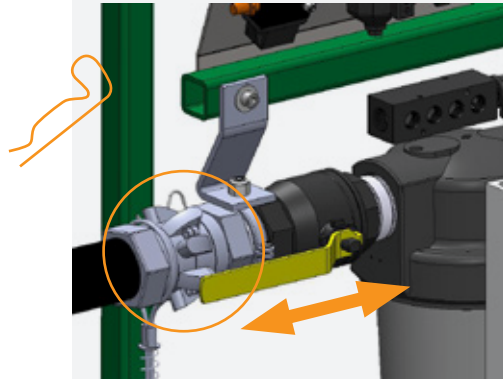

Pull out **Emergency Stop Button**.

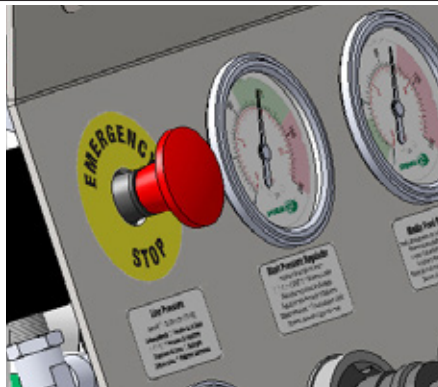

To begin blasting, unlock **Deadman Handle** by pressing down safety flap.



Press **Deadman Handle** down and wait 5 to 10 seconds for Sponge Media to flow.



Adjust **Blast Pressure** and **Media Feed Pressure** to desired levels.

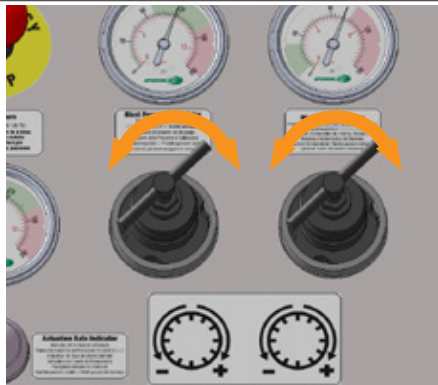

**Typical Media Feed Pressures**

**Nozzle Size**

**Sponge Media Recycles**

**Working Mix**

		1-3		4-6		7-12	
		bar	psi	bar	psi	bar	psi
#7	10mm (7/16in)	2.0	30	1.5	20	0.7	10
#8	12mm (1/2in)	2.8	40	2.0	30	1.5	20
#10	15mm (5/8in)	3.4	50	2.8	40	2.0	30
#12	18mm (3/4in)	4.1	60	3.4	50	2.8	40

Confirm **Manual Rotation Knob** is rotating and **Actuation Rate Indicator Eye** is functioning - by seeing it cycle between black and green.

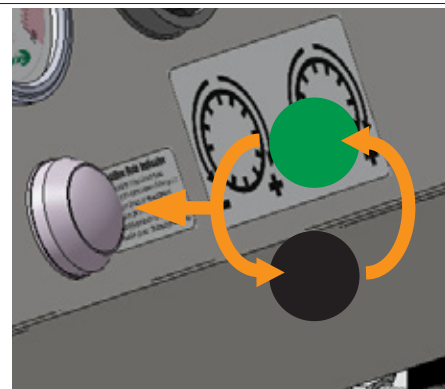
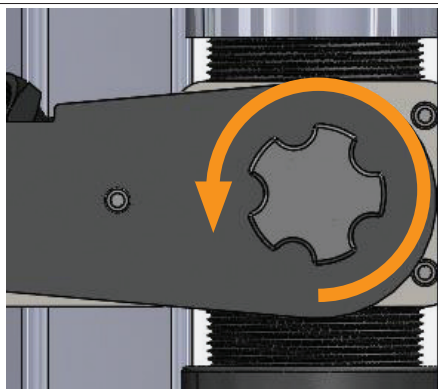

Prepare surface to desired condition.

## 4.2

## (Non-Maintenance) Shutdown of Unit

For normal shutdown during operation.

Release **Deadman Handle**.

OR

Push in **Emergency Stop Button**.

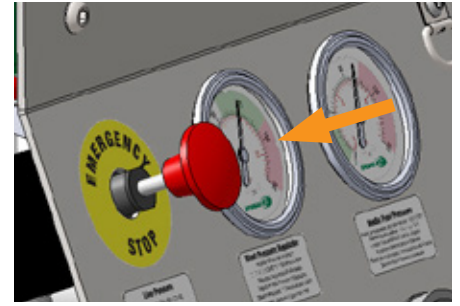

## 4.3

## (Maintenance/Long-Term) Shutdown of Unit

For shutdowns to conduct inspection, maintenance or for extended non-use.

Release Deadman Handle, then push in **Emergency Stop Button**.

Shut off inbound supply of air from its source.



Shut off **Main Air Ball Valve**.

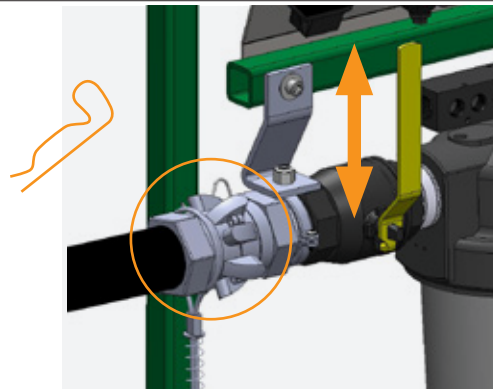

Open **Main Air Ball Valve**.

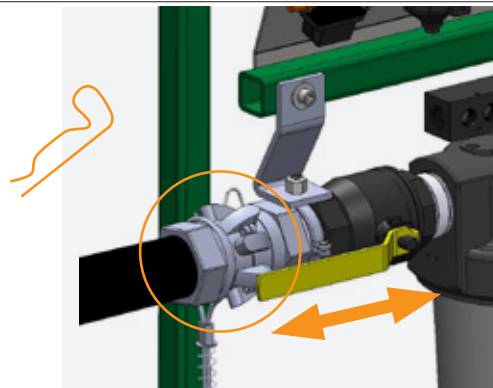

Point **Blast Nozzle** at working substrate (away from people); press safety flap and then press **Deadman Handle** down.

Keep **Deadman Handle** pressed down until all remaining air is vented.

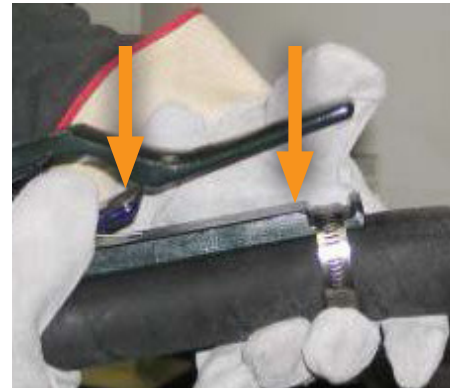

**WARNING**

Pressurized system. Release air pressure before servicing. Failure to comply may result in serious injury.

Once all **Control Panel** gauges read "0" bar (psi), confirm supply line to Unit is depressurized.

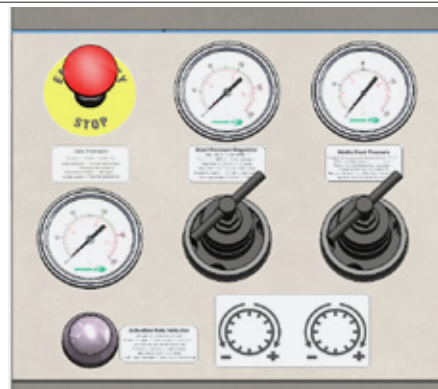

Close **Main Air Ball Valve**.

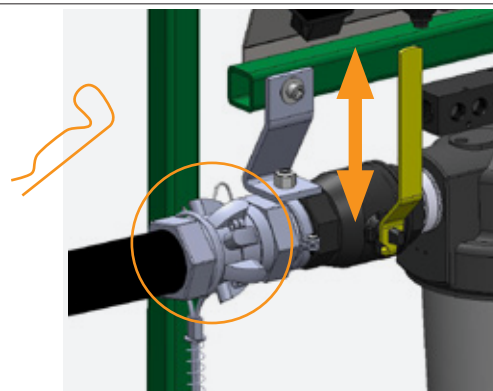



# 5.0

# MAINTENANCE

Routine maintenance is required to provide long and reliable equipment life. This Unit must be shut down and fully depressurized prior to any maintenance.



### WARNING

Pressurized system. Release air pressure before servicing. Failure to comply may result in serious injury.

## 5.1

### Prior to each use

Inspect **Blast Nozzle** for wear. Once nozzle throat has worn 1.5mm (1/16in) beyond its original intended diameter, it should be replaced.

Thoroughly inspect **Blast Hose** components and connections. Replace as needed. Ensure all couplings are properly equipped with coupling gaskets, wire and whip-checks.

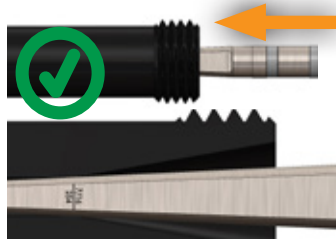

## 5.2

### Confirm adequate pneumatic tool oil is present in Air Motor Lubricator.

USE SAE 5W (ISO 32)  
NON-DETERGENT OIL ONLY.





## 5.3

### Performed monthly (or as needed)

Inspect and clean Exhaust Muffler. Replace when exhaust is slow. Remove any accumulated media in Exhaust Muffler and reinstall. **WARNING:** Do not operate equipment without Exhaust muffler in place.

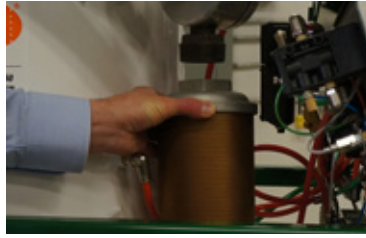

Remove **Auger Chain Guard** and inspect **Auger Drive Chain**.

Apply lightweight lubricating oil as necessary.

Replace **Auger Chain Guard**.

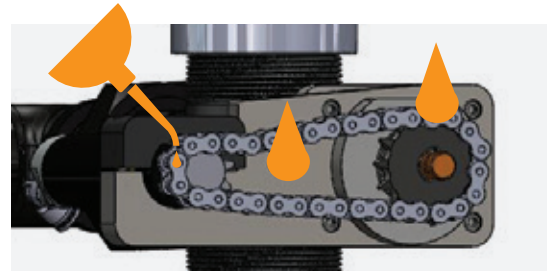

## 5.4

### Performed bi-monthly (or as needed)

Remove lower portion of **Secondary Water Separator**, **Control Panel Moisture Separator** and **Air Motor Moisture Separator**; inspect each interior and O-Ring.

Remove contaminants; replace O-Ring if needed and reinstall.



# 6.0

# TROUBLESHOOTING

## Unit does not operate when Deadman Handle is depressed

Check **Main Air Ball Valve** is open.

Check **Emergency Stop Button** is pulled out.

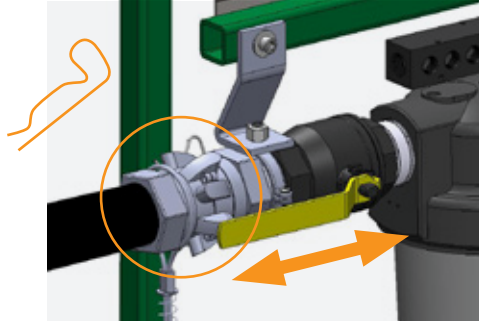

Check all **Twinline Quick Connect Fittings** are connected and secure.

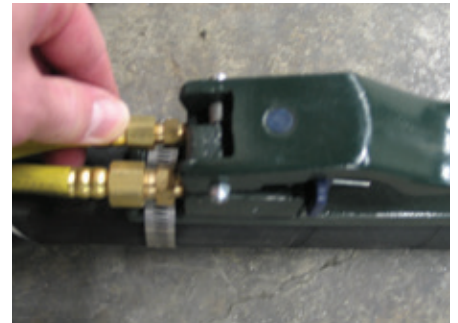

Check for damage to **Twinline**.



Check **Line Pressure** is adequate for operation using Section 3.1.

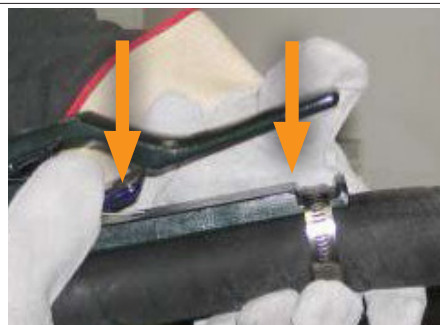

## Unit does not operate when Deadman Handle is pressed continued.

Remove red air line from **Exhaust Valve**; cover with thumb, then press **Deadman Handle** (down).

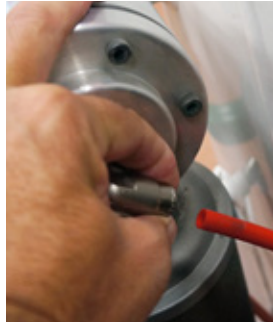

**IF no air** is felt exiting red air line, trace air flow operation through **Twinline** and **Deadman Handle** checking for obstructions or leaks.

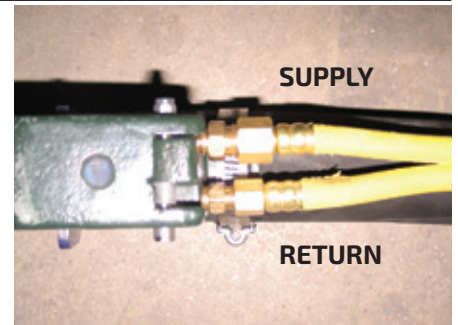

**IF air** is felt exiting red air line, place thumb on opening of red air line and press **Deadman Handle** (down).



**IF unit starts** (air exits nozzle) depressurize unit and replace **Exhaust Valve Diaphragm**.



# Air will not stop exiting nozzle when Deadman Handle is released

Push in **Emergency Stop Button**.



**If unit stops**, likely problems are:

1. Incorrect **Deadman**. Replace with Sponge-Jet **Deadman**.
2. Twinline air lines from unit to Deadman have been reversed.
3. **Deadman** is broken; replace with Sponge-Jet **Deadman**.

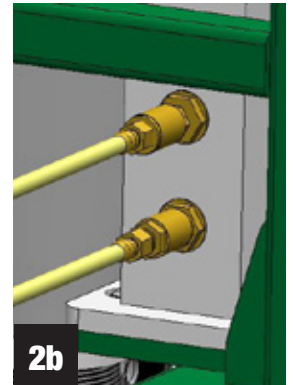

**If Unit does not stop**, likely problem is:

**On/Off Blast Pressure Regulator** is malfunctioning. Contact a Sponge-Jet representative



# Auger will not begin rotating

Check **Emergency Stop Button** is pulled out.



Confirm **Media Feed Pressure** Gauge reads consistently with **Typical Media Feed Pressure** label on Unit or in chart below.

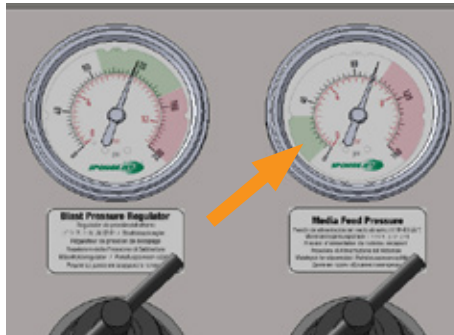

Typical Media Feed Pressure	
Media Feed Pressure	2.0 - 3.0 bar (30 - 45 psi)
Blind Pressure Regulator	2.0 - 3.0 bar (30 - 45 psi)

Nozzle Size	Sponge Media Recycles				Working Mix	
	1-3		4-6		7-12	
	bar	psi	bar	psi	bar	psi
#7 10mm (7/16in)	2.0	30	1.5	20	0.7	10
#8 12mm (1/2in)	2.8	40	2.0	30	1.5	20
#10 15mm (5/8in)	3.4	50	2.8	40	2.0	30
#12 18mm (3/4in)	4.1	60	3.4	50	2.8	40

Turn **Manual Rotation Knob** clockwise to confirm free rotation.

If excessive force is required, clear obstruction (see next section).

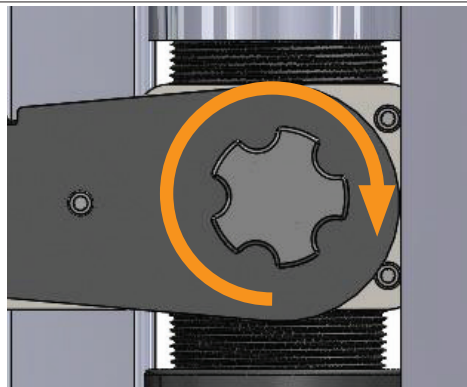



# Auger stops rotating during normal operation

1. Release **Deadman Handle** and depressurize unit.
2. Close **Main Air Ball Valve**.
3. Push in **Emergency Stop Button**.

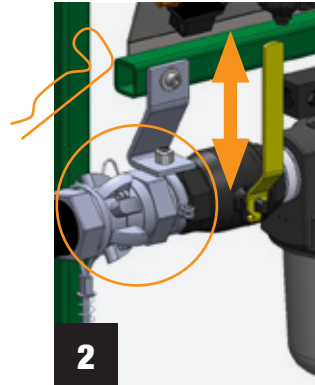

Remove **Clean Out Trap**.

Rotate **Manual Rotation Knob** clockwise and counter-clockwise until obstruction falls out.

**Auger** should move smoothly.

Replace **Clean Out Trap**.

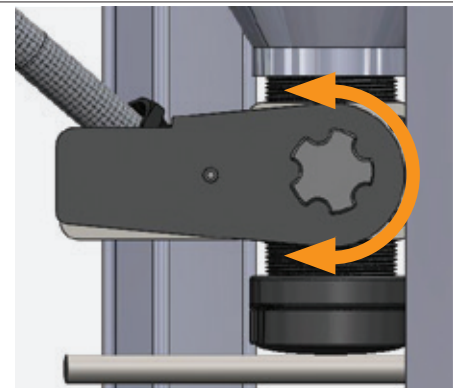
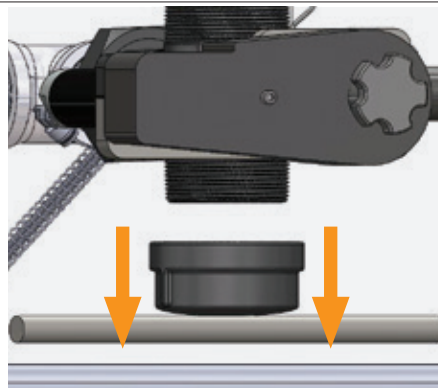

If obstruction cannot be cleared through **Clean Out Trap**:

Remove **Auger Chain Guard**.  
Remove (4) outside screws, pull **Auger** from unit and remove obstruction.

Reassemble **Auger**; replace (4) outside screws, and test for smooth rotation. Re-install **Auger Chain Guard**.

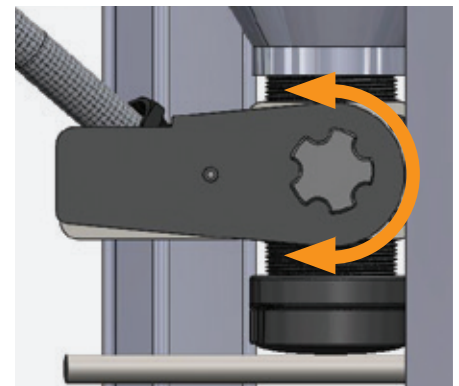
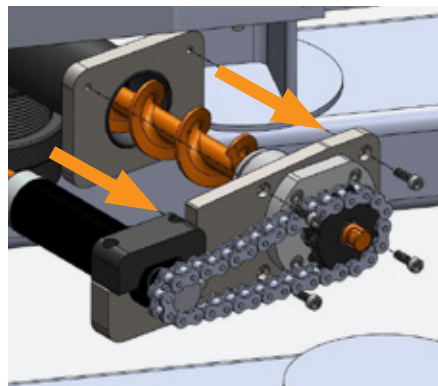
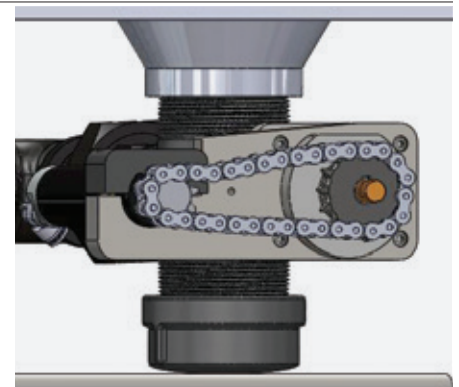
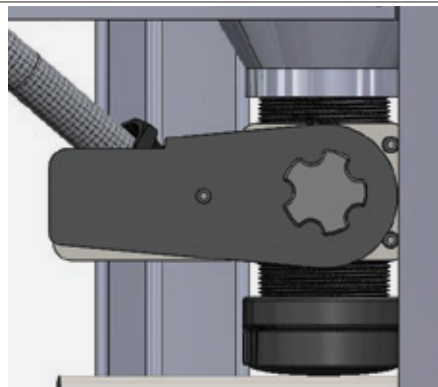

# Air Motor performs inconsistently at lower media pressures

1. Check **Air Motor Lubricator** oil level. Refill as necessary.

**USE SAE 5W (ISO 32)  
NON-DETERGENT OIL ONLY.**



## Air flow through nozzle suddenly stops

1. Do not restart. Immediately press in **Emergency Stop Button**.

2. Depressurize unit and close **Main Air Ball Valve**.

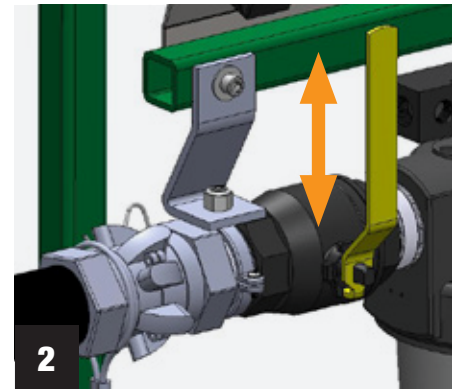
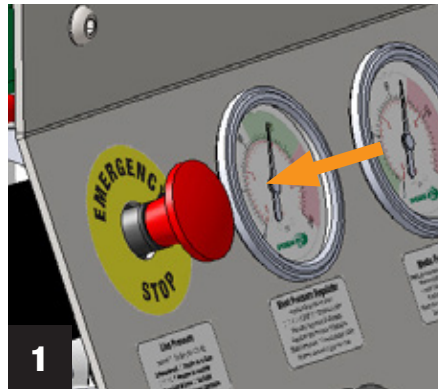

3. Remove **Blast Nozzle** from **Blast Hose**; inspect for and remove obstructions.

4. Disconnect all **Blast Hose** connections; inspect for and remove obstructions.

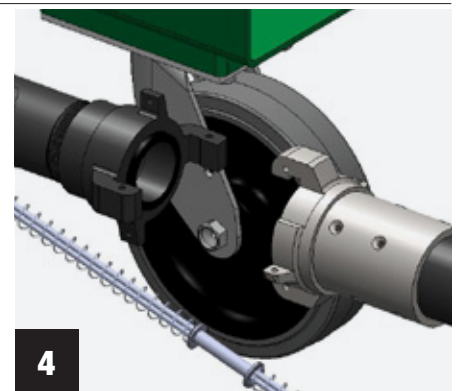

## Too much Sponge Media exits Nozzle or is pulsing

1. Check **Choke Valve** is in open.

2. Check **Media Feed Pressure** is within gauge recommended range (green).

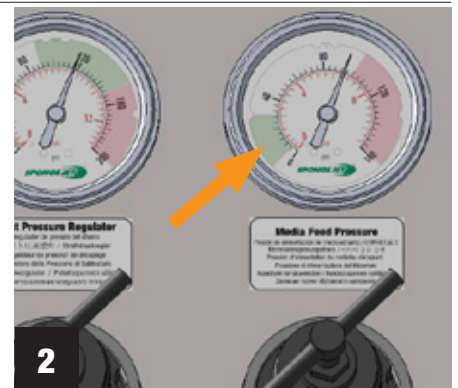
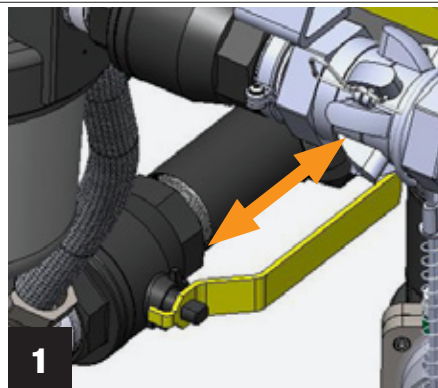

# Air will not stop exiting nozzle when Deadman Handle is released

Press in **Emergency Stop Button**.

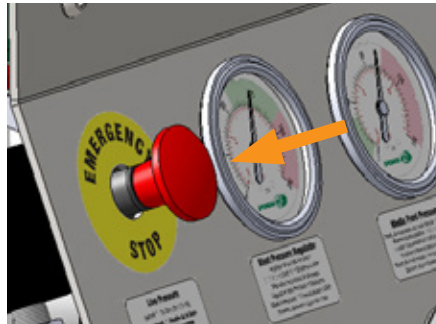

**IF UNIT STOPS**, likely problems are:

1. Incorrect **Deadman**.  
Replace with Sponge-Jet **Deadman**.
2. **Twinline** air lines from unit to **Deadman** have been reversed.
3. **Deadman** is broken; replace with Sponge-Jet **Deadman**.

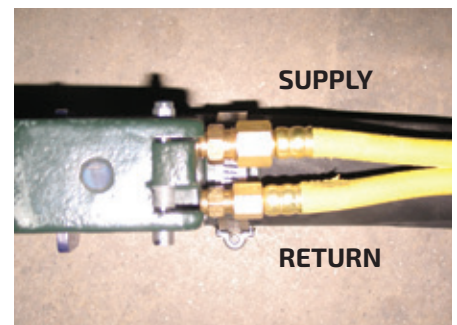
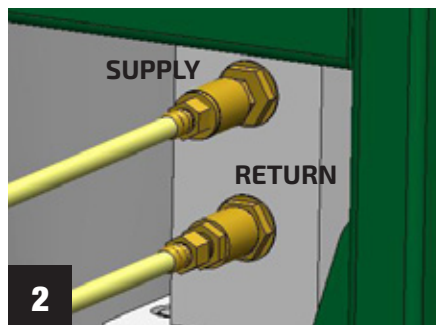

---

## Blast Pressure continuously increases and decreases or Unit exhausts intermittently while blasting

1. Check for damage to **Twinline** and for air leaks at all fittings and connections.

Repair, replace or tighten as necessary.





# Air flows through Nozzle without Sponge Media while Auger is rotating

Check cycling of **Actuation Rate Indicator Eye** and for light pulse of air exiting front face of **Timer**. Confirm **Timer** is set between 1.25-1.5.

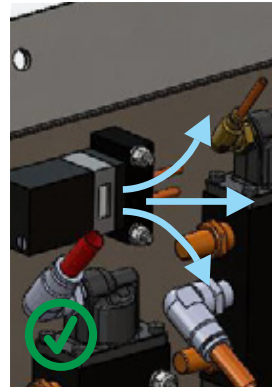
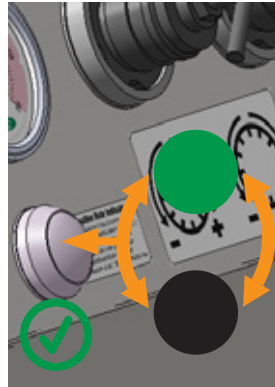

If **Actuation Rate Indicator Eye** and **Timer** produces light pulse of air, resume blasting.

If no light pulse of air is exiting side of **Timer**...

Remove (2) nuts from **Timer** base, then remove (2) screws from **Timer** face; replace the **Timer**, matching airline positions prior to removal.

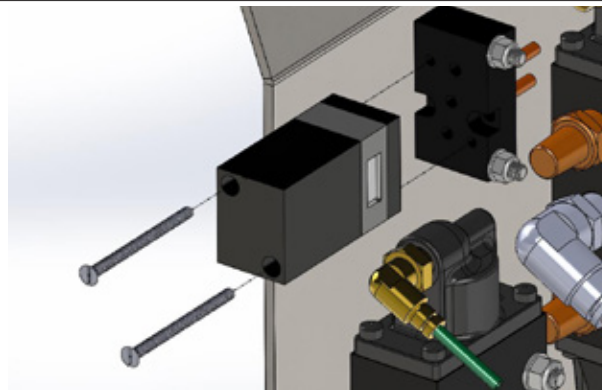

Confirm proper motion of **Actuation Indicator Eye** and a 45° back-and-forth motion of **Actuator Tree and Chain**.

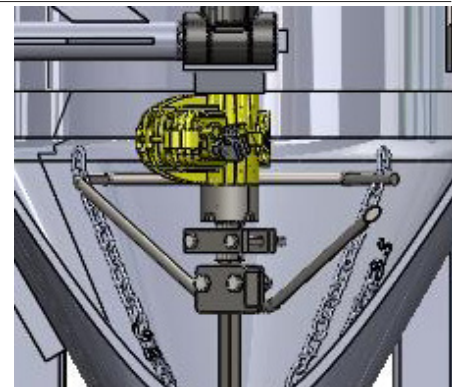
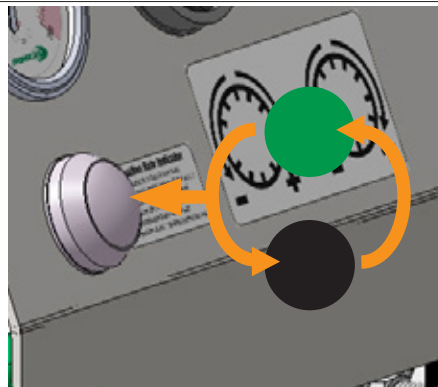

---

# NOTES

---

**MODEL**

---

**SERIAL**

---